

Client \_\_\_\_\_ Quantity \_\_\_\_\_  
 Project \_\_\_\_\_ Position \_\_\_\_\_

## Storage Vision counter with 2 doors

**Model:** TCA13/1MJ-710

**Cod:** T60202000201

Vision storage counter 2 doors, counter body height 710 mm, top with splashback. Plug-in refrigeration unit, 5 heavy duty climatic class and R290 ecological refrigerant gas. temperature range -5°+15°C. Adjustable ventilation 50-100% and adjustable humidity 45-95% for the chocolate function. 7" touch screen and operating mode with customisable recipes. Equipment: 14 pairs of guides for EN60x40 trays. It is equipped with the functions: storage, thawing, chocolate. Anti-corrosion treated evaporator and hot gas defrosting. 60 mm insulation thickness - HFO with high insulation performance and low environmental impact (CFC, HCFC, HFC free). AISI 304 stainless steel handle and magnetic triple chamber door gasket, easily replaceable. Reversible, self-closing door opening with 105° stop. AISI 304 stainless steel interior/exterior including external back. Rounded inner corners for easy cleaning. The reinforced modular base in colaminated steel allows installation on wheels, feet, mobile or masonry plinths. Cosmo: wi-fi connection for remote monitoring via Cosmo App. When wired to Coldline counters and cabinets acts as a hub for remote monitoring of connected equipment.



### Technical data

<b>Top:</b>	With top and splashback
<b>Max capacity:</b>	14 trays EN60x40
<b>Gross capacity:</b>	389 lt
<b>Temperature range:</b>	-5°+15°C
<b>Humidity range:</b>	90% - 40% (T°C >+4°C)
<b>Refrigerant unit:</b>	Plug-in
<b>Cooling gas:</b>	R290
<b>Defrost:</b>	Hot gas
<b>Body height:</b>	710 mm
<b>Valve:</b>	Supplied standard with solenoid
<b>Dimensions:</b>	1450×800×950 mm
<b>Packing dimensions:</b>	1545×900×998 mm
<b>Gross weight:</b>	160 Kg
<b>Voltage:</b>	220-240 V - 50 Hz
<b>Total rate:</b>	550 W
<b>Absorbed Current:</b>	2,5 A
<b>Cooling capacity:</b>	565 W*
<b>*:</b>	Evap. -10°C Cond. +55°C

### Features

<b>Functions:</b>	Storage, chocolate, thawing, ice cream
<b>Standard equipment:</b>	14 slides EN60x40
<b>Control:</b>	7" touch screen display with USB port
<b>Doors:</b>	2 doors, self-closing, reversible with 105° stop
<b>Door gasket:</b>	Magnetic, triple chamber and easily replaceable
<b>Insulation:</b>	60 mm thickness - CFC/HCFC free
<b>Exterior/interior finishing:</b>	Exterior and interior AISI 304 stainless steel.
<b>Inner corners:</b>	Rounded for easy cleaning and ensuring maximum hygiene
<b>Handle:</b>	Stainless steel AISI 304, 2 mm thick
<b>Racks and slides:</b>	Stainless steel AISI 304, quick release
<b>Feets:</b>	AISI 304 stainless steel adjustable h 100/150 mm
<b>Cosmo:</b>	Wi-Fi remote control system

## Accessories and variants

RAL customisable colouring	Aluminium coated backingan EN60x40 h 20 mm
Plug-in water unit	Stainless steel shelf EN60x40
Alimentazione frequenza 60Hz	Plastic coated shelf EN60x40
Other special voltage	Pair of type L slides 402 mm EN
4 Swivel and brake castors h 128 mm	Serial interface, RS485 cable

## COSMO - wi-fi control

Cosmo is The Nice Kitchen's exclusive wi-fi technology that allows VISION storage units to be connected, updated and monitored from smartphones. VISION is also a Cosmo hub and allows remote supervision of the Coldline appliances connected to it. From the CosmoApp you can check the operating conditions of each machine and receive alerts in the event of abnormal operation.

## Technical draw

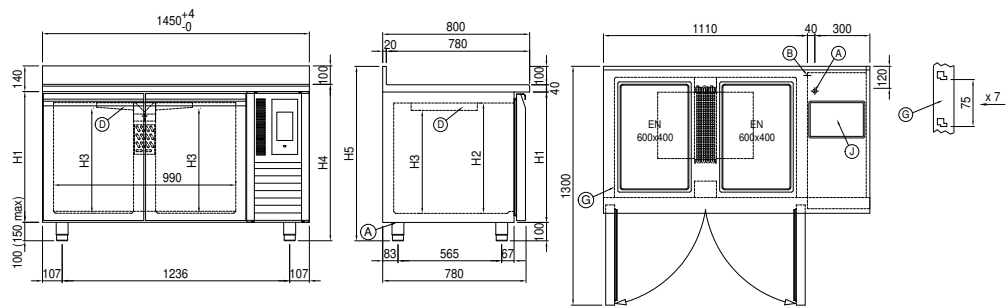

**A:** Power supply cable outlet

**B:** Condensation water drain

**D:** Airflow conveyor

**G:** Racks pitch

**J:** Automatic evaporation of condensing water