

Client \_\_\_\_\_ Quantity \_\_\_\_\_  
 Project \_\_\_\_\_ Position \_\_\_\_\_

## Retarder-prover Vision counter with 2 doors

**Model:** TFP13/1MJ-710

**Cod:** T60261000801

Vision retarder prover 2 doors, counter body height 710 mm, with top. Plug-in refrigeration unit, 5 heavy duty climatic class and R290 ecological refrigerant gas. temperature range -6°+40°C. adjustable ventilation 25-100% and adjustable humidity 45-95%. 7" touch screen and operating mode with customisable recipes. Equipment: 14 pairs of slides for EN60x40 trays, water purification filter. It is equipped with the functions: retarded proving, manual proving, continuous cycle, storage, thawing, chocolate. Anti-corrosion treated evaporator and hot gas defrosting. 60 mm insulation thickness - HFO with high insulation performance and low environmental impact (CFC, HCFC, HFC free). AISI 304 stainless steel handle and magnetic triple chamber door gasket, easily replaceable. Reversible, self-closing door opening with 105° stop. AISI 304 stainless steel interior/exterior including external back. Rounded inner corners for easy cleaning. The reinforced modular base in colaminated steel allows installation on wheels, feet, mobile or masonry plinths. Cosmo: wi-fi connection for remote monitoring via Cosmo App. When wired to Coldline counters and cabinets acts as a hub for remote monitoring of connected equipment.



### Technical data

<b>Top:</b>	With top
<b>Max capacity:</b>	14 trays EN60x40
<b>Gross capacity:</b>	389 lt
<b>Temperature range:</b>	-6°+40°C
<b>Humidity range:</b>	45% - 95% with humidifier
<b>Humidifier:</b>	Including
<b>Refrigerant unit:</b>	Plug-in
<b>Cooling gas:</b>	R290
<b>Defrost:</b>	Hot gas
<b>Body height:</b>	710 mm
<b>Valve:</b>	Supplied standard with solenoid
<b>Dimensions:</b>	1450×800×850 mm
<b>Packing dimensions:</b>	1545×900×998 mm
<b>Gross weight:</b>	165 Kg
<b>Voltage:</b>	220-240 V - 50 Hz
<b>Total rate:</b>	550 W
<b>Absorbed Current:</b>	2,5 A
<b>Cooling capacity:</b>	565 W*
<b>*:</b>	Evap. -10°C Cond. +55°C

### Features

<b>Functions:</b>	Retarder prover, manual proving, continuous cycle, storage, chocolate, thawing, ice cream
<b>Standard equipment:</b>	14 slides EN60x40
<b>Control:</b>	7" touch screen display with USB port
<b>Doors:</b>	2 doors, self-closing, reversible with 105° stop
<b>Door gasket:</b>	Magnetic, triple chamber and easily replaceable
<b>Insulation:</b>	60 mm thickness - CFC/HCFC free
<b>Exterior/interior finishing:</b>	Exterior and interior AISI 304 stainless steel.
<b>Inner corners:</b>	Rounded for easy cleaning and ensuring maximum hygiene
<b>Handle:</b>	Stainless steel AISI 304, 2 mm thick
<b>Racks and slides:</b>	Stainless steel AISI 304, quick release
<b>Feets:</b>	AISI 304 stainless steel adjustable h 100/150 mm
<b>Cosmo:</b>	Wi-Fi remote control system

## Accessories and variants

RAL customisable colouring	4 Swivel and brake castors h 128 mm
Plug-in water unit	Aluminium coated backingan EN60x40 h 20 mm
Alimentazione frequenza 60Hz	Stainless steel shelf EN60x40
Other special voltage	Plastic coated shelf EN60x40
Purity C Quell ST 50 filter cartridge	Pair of type L slides 402 mm EN

## COSMO - wi-fi control

Cosmo is The Nice Kitchen's exclusive wi-fi technology that allows VISION retarder provers to be connected, updated and monitored from smartphones. VISION is also a Cosmo hub and allows remote supervision of the Coldline appliances connected to it. From the CosmoApp you can check the operating conditions of each machine and receive alerts in the event of abnormal operation.

## Technical draw

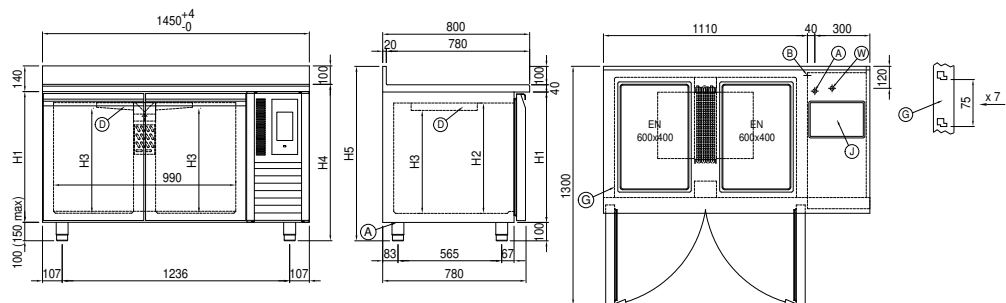

**A:** Power supply cable outlet

**B:** Condensation water drain

**D:** Airflow conveyor

**G:** Racks pitch

**J:** Automatic evaporation of condensing water

**W:** Water mains connection for humidifier - 3/4" female. Unloading not required