

Client _____ Quantity _____
 Project _____ Position _____

Storage Vision counter with 3 doors

Model: TCA17/1MJ-710

Cod: T60302000201

Vision storage counter 3 doors, counter body height 710 mm, top with splashback. Plug-in refrigeration unit, 5 heavy duty climatic class and R290 ecological refrigerant gas. temperature range -5°+15°C. Adjustable ventilation 50-100% and adjustable humidity 45-95% for the chocolate function. 7" touch screen and operating mode with customisable recipes. Equipment: 21 pairs of slides for EN60x40 trays. It is equipped with the functions: storage, thawing, chocolate. Anti-corrosion treated evaporator and hot gas defrosting. 60 mm insulation thickness - HFO with high insulation performance and low environmental impact (CFC, HCFC, HFC free). AISI 304 stainless steel handle and magnetic triple chamber door gasket, easily replaceable. Reversible, self-closing door opening with 105° stop. AISI 304 stainless steel interior/exterior including external back. Rounded inner corners for easy cleaning. The reinforced modular base in colaminated steel allows installation on wheels, feet, mobile or masonry plinths. Cosmo: wi-fi connection for remote monitoring via Cosmo App. When wired to Coldline counters and cabinets acts as a hub for remote monitoring of connected equipment.



Technical data

Top:	With top and splashback
Max capacity:	21 trays EN60x40
Gross capacity:	607 lt
Temperature range:	-5°+15°C
Humidity range:	90% - 40% (T°C > +4°C)
Refrigerant unit:	Plug-in
Energetic class:	D
Energy efficiency index:	56,0
Annual consumption:	1544
24h consumption:	4232
Climate class:	5
Cooling gas:	R290 (GWP=3)
Refrigerant Charge:	110g
Defrost:	Hot gas
Body height:	710 mm
Valve:	Supplied standard with solenoid
Dimensions:	2005×800×950 mm
Packing dimensions:	2100×900×998 mm
Net / gross weight:	190 Kg / 200 Kg
Net / gross volume:	382 lt / 607 lt
Voltage:	220-240 V - 50 Hz
Total rate:	550W - 2,5A
Cooling capacity:	565 W*
*:	Evap. -10°C Cond. +55°C

Features

Functions:	Storage, chocolate, thawing, ice cream
Standard equipment:	21 slides EN60x40
Control:	7" touch screen display with USB port
Doors:	3 doors, self-closing, reversible with 105° stop
Door gasket:	Magnetic, triple chamber and easily replaceable
Insulation:	60 mm thickness - CFC/HCFC free
Exterior/interior finishing:	Exterior and interior AISI 304 stainless steel.
Inner corners:	Rounded for easy cleaning and ensuring maximum hygiene
Handle:	Stainless steel AISI 304, 2 mm thick
Racks and slides:	Stainless steel AISI 304, quick release
Feets:	AISI 304 stainless steel adjustable h 100/150 mm
Cosmo:	Wi-Fi remote control system

In order to constantly offer the best possible products we reserve the right to make changes on technical specifications without incurring any obligation for equipment previously or subsequently sold.

Accessories and variants

RAL customisable colouring	Aluminium coated backingan EN60x40 h 20 mm
Plug-in water unit	Stainless steel shelf EN60x40
Alimentazione frequenza 60Hz	Plastic coated shelf EN60x40
Other special voltage	Pair of type L slides 402 mm EN
6 Swivel and brake castors h 128 mm	Serial interface, RS485 cable

COSMO - wi-fi control

Cosmo is The Nice Kitchen's exclusive Wi-Fi technology that allows VISION storage units to be connected, updated and monitored from smartphones. VISION is also a Cosmo hub and allows remote supervision of the Coldline appliances connected to it. From the CosmoApp you can check the operating conditions of each machine and receive alerts in the event of abnormal operation.

Technical draw

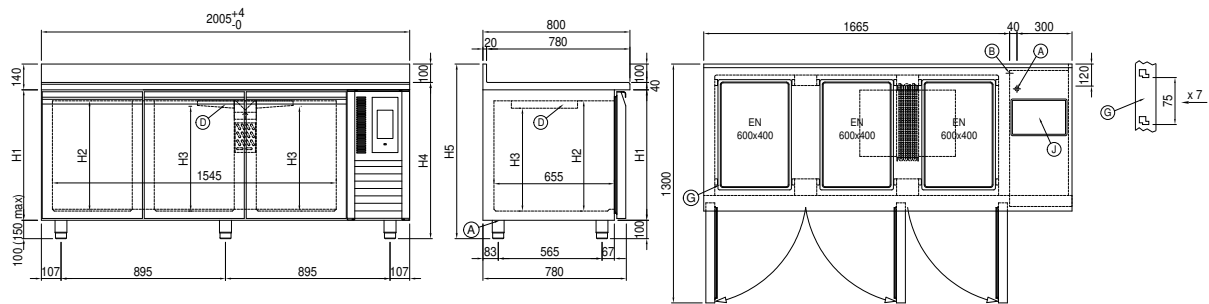

- | | | |
|------------------------------|--|---------------------|
| A: Power supply cable outlet | B: Condensation water drain | D: Airflow conveyor |
| G: Racks pitch | J: Automatic evaporation of condensing water | |