

Client _____ Quantity _____
 Project _____ Position _____

Retarder-prover Vision counter with 3 doors

Model: TFP17/1MJ-710

Cod: T60361000801

Vision retarder prover 3 doors, counter body height 710 mm, with top. Plug-in refrigeration unit, 5 heavy duty climatic class and R290 ecological refrigerant gas. temperature range -6°+40°C. adjustable ventilation 25-100% and adjustable humidity 45-95%. 7" touch screen and operating mode with customisable recipes. Equipment: 21 pairs of slides for EN60x40 trays. It is equipped with the functions: retarded proving, manual proving, continuous cycle, storage, thawing, chocolate. Anti-corrosion treated evaporator and hot gas defrosting. 60 mm insulation thickness - HFO with high insulation performance and low environmental impact (CFC, HCFC, HFC free). AISI 304 stainless steel handle and magnetic triple chamber door gasket, easily replaceable. Reversible, self-closing door opening with 105° stop. AISI 304 stainless steel interior/exterior including external back. Rounded inner corners for easy cleaning. The reinforced modular base in colaminated steel allows installation on wheels, feet, mobile or masonry plinths. Cosmo: wi-fi connection for remote monitoring via Cosmo App. When wired to Coldline counters and cabinets acts as a hub for remote monitoring of connected equipment.



Technical data

Top:	With top
Max capacity:	21 trays E
Gross capacity:	607 lt
Temperature range:	-6°+40°C
Humidity range:	45% - 95% with humidifier
Humidifier:	Including
Refrigerant unit:	Plug-in
Energetic class:	D
Energy efficiency index:	56,0
Annual consumption:	1544
24h consumption:	4232
Climate class:	5
Cooling gas:	R290 (GWP=3)
Defrost:	Hot gas
Body height:	710 mm
Valve:	Supplied standard with solenoid
Dimensions:	2005×800×850 mm
Packing dimensions:	2100×900×998 mm
Net / gross weight:	190 Kg / 200 Kg
Net / gross volume:	382 lt / 607 lt
Voltage:	220-240 V - 50 Hz
Total rate:	550W - 2,5A
Cooling capacity:	565 W*
*:	Evap. -10°C Cond. +55°C

Features

Functions:	Retarder prover, manual proving, continuous cycle, storage, chocolate, thawing, ice cream
Standard equipment:	21 slides EN60x40
Control:	7" touch screen display with USB port
Doors:	3 doors, self-closing, reversible with 105° stop
Door gasket:	Magnetic, triple chamber and easily replaceable
Insulation:	60 mm thickness - CFC/HCFC free
Exterior/interior finishing:	Exterior and interior AISI 304 stainless steel.
Inner corners:	Rounded for easy cleaning and ensuring maximum hygiene
Handle:	Stainless steel AISI 304, 2 mm thick
Racks and slides:	Stainless steel AISI 304, quick release
Feets:	AISI 304 stainless steel adjustable h 100/150 mm
Cosmo:	Wi-Fi remote control system

In order to constantly offer the best possible products we reserve the right to make changes on technical specifications without incurring any obligation for equipment previously or subsequently sold.

Accessories and variants

RAL customisable colouring	6 Swivel and brake castors h 128 mm
Plug-in water unit	Aluminium coated backingan EN60x40 h 20 mm
Alimentazione frequenza 60Hz	Stainless steel shelf EN60x40
Other special voltage	Plastic coated shelf EN60x40
Purity C Quell ST 50 filter cartridge	Pair of type L slides 402 mm EN

COSMO - wi-fi control

Cosmo is The Nice Kitchen's exclusive wi-fi technology that allows VISION retarder provers to be connected, updated and monitored from smartphones. VISION is also a Cosmo hub and allows remote supervision of the Coldline appliances connected to it. From the CosmoApp you can check the operating conditions of each machine and receive alerts in the event of abnormal operation.

Technical draw

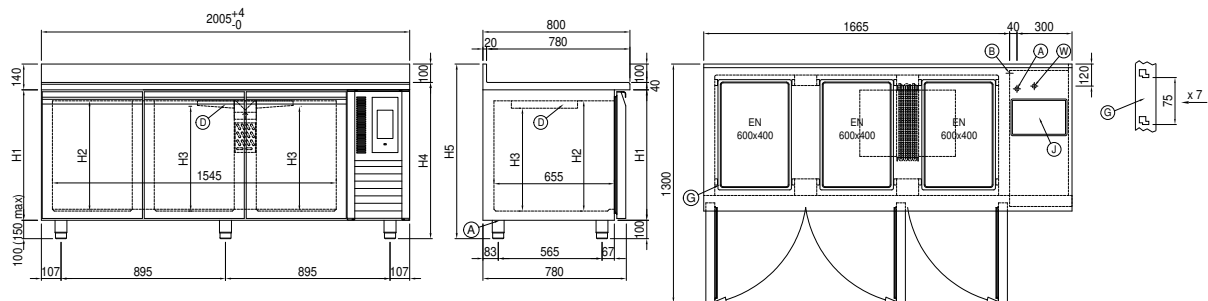

- | | | | | | |
|----|---------------------------|----|---|----|---|
| A: | Power supply cable outlet | B: | Condensation water drain | D: | Airflow conveyor |
| G: | Racks pitch | J: | Automatic evaporation of condensing water | W: | Water mains connection for humidifier - 3/4" female. Unloading not required |

In order to constantly offer the best possible products we reserve the right to make changes on technical specifications without incurring any obligation for equipment previously or subsequently sold.