

Client _____ Quantity _____
 Project _____ Position _____

Vision Industry W50LK NUVO

Model: W50LKHR

Cod: W82120312002



Vision Industry W50L trolley blast chiller Roll-In NUVO version, temperature range -40°+85°C with humidifier boiler as standard. It is equipped with the functions: blast chilling, blast freezing, manual cycle, thawing, proving, retarded proving, holding, steam pasteurisation, low temperature cooking with steam, steam sanitising. Remote cooling system with R452a refrigerant gas. Devote™ - Dynamic Evolution Temperature - the innovative system that autonomously recognises the weight, size and temperature of food and automatically shortens the blast chilling or freezing time of hot food without the use of a core probe. Patented NUVO™ technology for cooking food at low temperatures using steam and sequencing blast chilling or blast freezing cycles. 7" touch screen and operating mode with customisable recipes, by time, with core probe or with Devote algorithm. Adjustable ventilation 25-100%, adjustable humidity 45-95%. Blast chilling yield +90/+3°C - 200 Kg; blast freezing yield +90/-18°C - 160 Kg. 5 heavy duty climatic class, forced air defrost. 100 mm insulation thickness - HFO with high insulation performance and low environmental impact (CFC, HCFC, HFC free). Electronic expansion valve and anti-corrosion painted evaporator. Compensation valve to reduce waiting times during frequent door openings. Easily replaceable triple chamber magnetic gasket, core probe with screw connector and led lighting. Exterior and interior AISI 304 stainless steel, interior made of "canvas" steel with special highly durable texture. fan unit and condenser cover removable without tools. Blast chiller supplied assembled. ModBus/RTU Rs485 connection as standard. Cosmo: wi-fi connection for remote monitoring via Cosmo App. When wired to Coldline counters and cabinets acts as a hub for remote monitoring of connected equipment.

Technical data

| | |
|---------------------|----------------------------|
| Max capacity: | 1 trolley |
| Temperature range: | -40°+85°C |
| Ventilation range: | 25% - 100% |
| Humidity range: | 45% - 95% with humidifier |
| Humidifier: | Including |
| Refrigerant unit: | remote |
| Yield +90/+3: | 200 Kg |
| Yield +90/-18: | 160 Kg |
| Cooling gas: | R404/R452 |
| Defrost: | Forced air |
| Valve: | Electronic expansion valve |
| Dimensions: | 1850×1430×2510 mm |
| Packing dimensions: | 1985×1695×2550 mm |
| Net / gross weight: | 463 Kg / 508 Kg |
| Net / gross volume: | / |
| Voltage: | 400-415 V - 50-60 Hz |
| Total rate: | 8270 W - 17,30 A |
| Cooling capacity: | 22980 W* |
| *: | Evap. -10°C Cond. +45°C |

Features

| | |
|------------------------------|--|
| Functions: | Blast chilling, shock freezing, thawing, proving and retarder prover, holding, steam pasteurisation, low temperature steam cooking, steam sanitizing, manual steam cycle |
| Control: | 7" touch screen display with USB port |
| Door gasket: | Magnetic, triple chamber and easily replaceable |
| Core probe: | Needle probe with 1 reading point, quick-release and easily replaceable |
| Insulation: | 100 mm thickness - CFC/HCFC free |
| Exterior/interior finishing: | Internal and external in "linen canvas" steel |
| Inner corners: | Rounded base 20 mm |
| Handle: | In AISI 304 stainless steel |
| Cosmo: | Wi-Fi remote control system |

Accessories and variants

| | |
|--|---|
| Abbattitore fornito smontato | Silenced faired remote condensing unit 4NES-14Y |
| Floor 20 mm high, ramp included | Faired unit with remote condenser 4NES-14Y |
| Reverse door opening from standard | PVC ventilation profiles W50LK |
| Door opening turning and control panel inversion | Ramp 100 mm high. Length 913 mm W50L |
| Door stop 100° | Ramp 140 mm high. Length 1390 mm W50L |
| Sonda al cuore 3 punti di lettura | Trolley GN1/1 20 trays 598x530x1630 mm |
| Sonda al cuore riscaldata 1 punto di lettura | Trolley EN60x40 20 trays 460x620x1750 mm |
| Winter kit -20°C | Trolley GN2/1 20 trays 660x720x1750 mm |
| Winter kit -40°C | Trolley EN60x80 20 trays 660x820x1750 mm |
| Other special voltage | Purity C Quell ST 50 filter cartridge |
| Open remote condensing unit 4NES-14Y | Sanitizing detergent |

Remote unit technical data

| | |
|-----------------------------------|-------------------------|
| Voltage: | 400-415 V 3N - 50 Hz |
| Assorbimento Unità Remota: | 11,1kW - 22,1A |
| Cooling gas: | R404-R452a |
| HP unit: | 14 |
| Gross weight: | 300 Kg |
| Dimensions: | 1315x870x852 mm |
| Pipe delivery: | 12 mm |
| Pipe suction: | 42 mm |
| Cooling capacity: | Evap. -10°C Cond. +45°C |

COSMO - wi-fi control

Cosmo is The Nice Kitchen's exclusive wi-fi technology that allows VISION blast chillers to be connected, updated and monitored from smartphones. VISION is also a Cosmo hub and allows remote supervision of the Coldline appliances connected to it. From the CosmoApp you can check the operating conditions of each machine and receive alerts in the event of abnormal operation.

Technical draw

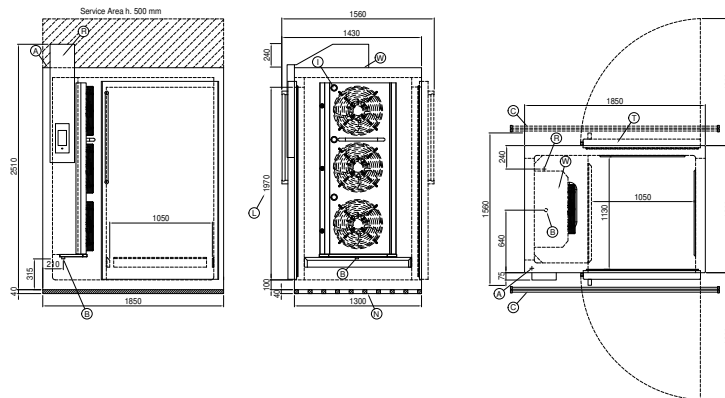

| | | | | | |
|----|---------------------------|----|------------------------------|----|---|
| A: | Power supply cable outlet | B: | Condensation water drain | C: | Floor grid for condensate drainage (recommended) |
| I: | Internal led lighting | L: | Door clear opening dimension | N: | PVC ventilation profiles |
| R: | Gas output pipes | T: | Pass-through version | W: | Water mains connection for humidifier - 3/4" female. Unloading not required |

In order to constantly offer the best possible products we reserve the right to make changes on technical specifications without incurring any obligation for equipment previously or subsequently sold.