

Client \_\_\_\_\_ Quantity \_\_\_\_\_  
 Project \_\_\_\_\_ Position \_\_\_\_\_

## Vision Industry W35K U

**Model:** W35KU

**Cod:** W83110112002



Vision Industry W35 trolley blast chiller Roll-In U version, temperature range -40°+10°C. It is equipped with the functions: blast chilling, blast freezing, manual cycle. Plug-In refrigeration system with air condensation with R452a refrigerant gas. Devote™ - Dynamic Evolution Temperature - the innovative system that autonomously recognises the weight, size and temperature of food and automatically shortens the blast chilling or freezing time of hot food without the use of a core probe. 7" touch screen and operating mode with customisable recipes, by time, with core probe or with Devote algorithm. Adjustable ventilation 25-100%. Blast chilling yield +90/+3°C - 85 Kg; blast freezing yield +90/-18°C - 60 Kg. 5 heavy duty climatic class, forced air defrost. 100 mm insulation thickness - HFO with high insulation performance and low environmental impact (CFC, HCFC, HFC free). Electronic expansion valve and anti-corrosion painted evaporator. Compensation valve to reduce waiting times during frequent door openings. Easily replaceable triple chamber magnetic gasket, core probe with screw connector and led lighting. Exterior and interior AISI 304 stainless steel, interior made of "canvas" steel with special highly durable texture. fan unit and condenser cover removable without tools. Blast chiller supplied assembled. ModBus/RTU Rs485 connection as standard. Cosmo: wi-fi connection for remote monitoring via Cosmo App. When wired to Coldline counters and cabinets acts as a hub for remote monitoring of connected equipment.

### Technical data

<b>Max capacity:</b>	1 trolley GN1/1, EN60x40
<b>Temperature range:</b>	-40°+10°C
<b>Ventilation range:</b>	25% - 100%
<b>Humidifier:</b>	Not available
<b>Refrigerant unit:</b>	Plug-in
<b>Yield +90/+3:</b>	85 Kg
<b>Yield +90/-18:</b>	60 Kg
<b>Climate class:</b>	5
<b>Cooling gas:</b>	R404/R452
<b>Defrost:</b>	Forced air
<b>Valve:</b>	Electronic expansion valve
<b>Dimensions:</b>	1230×1200×2770 mm
<b>Packing dimensions:</b>	1464×1364×2550 mm
<b>Gross weight:</b>	410 Kg
<b>Voltage:</b>	400-415 V - 50 Hz
<b>Total rate:</b>	6260 W
<b>Absorbed Current:</b>	17,65 A
<b>Cooling capacity:</b>	9100 W*
<b>*:</b>	Evap. -10°C Cond. +45°C

### Features

<b>Functions:</b>	Blast chilling, shock freezing, continuous cycle
<b>Control:</b>	7" touch screen display with USB port
<b>Door gasket:</b>	Magnetic, triple chamber and easily replaceable
<b>Core probe:</b>	Needle probe with 1 reading point, quick-release and easily replaceable
<b>Insulation:</b>	100 mm thickness - CFC/HCFC free
<b>Exterior/interior finishing:</b>	Internal and external in "linen canvas" steel
<b>Inner corners:</b>	Rounded base 20 mm
<b>Handle:</b>	In AISI 304 stainless steel
<b>Cosmo:</b>	Wi-Fi remote control system

## Accessories and variants

Abbottoire fornito smontato	Other special voltage
Floor 20 mm high, ramp included	PVC ventilation profiles W35K
Reverse door opening from standard	Ramp 100 mm high. Length 913 mm W35
Door opening turning and control panel inversion	Ramp 140 mm high. Length 1390 mm W35
Door stop 100°	Trolley GN1/1 20 trays 598x530x1630 mm
Sonda al cuore 3 punti di lettura	Trolley EN60x40 20 trays 460x620x1750 mm
Sonda al cuore riscaldata 1 punto di lettura	Purity C Quell ST 50 filter cartridge
Winter kit -20°C	Sanitizing detergent
Winter kit -40°C	Sterilizing UV lamp

## COSMO - wi-fi control

Cosmo is The Nice Kitchen's exclusive wi-fi technology that allows VISION blast chillers to be connected, updated and monitored from smartphones. VISION is also a Cosmo hub and allows remote supervision of the Coldline appliances connected to it. From the CosmoApp you can check the operating conditions of each machine and receive alerts in the event of abnormal operation.

## Technical draw

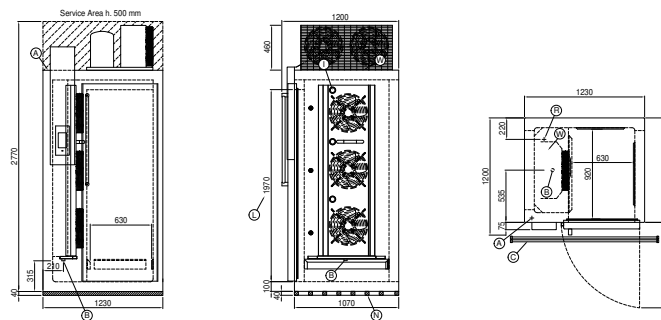

<b>A:</b> Power supply cable outlet	<b>B:</b> Condensation water drain	<b>C:</b> Floor grid for condensate drainage (recommended)
<b>I:</b> Internal led lighting	<b>L:</b> Door clear opening dimension	<b>N:</b> PVC ventilation profiles
<b>W:</b> Water mains connection for humidifier - 3/4" female. Unloading not required		