

Client _____ Quantity _____
 Project _____ Position _____

Smart 700 XL cabinet

Model: AS70/1MER

Cod: A12071200102



Smart 700XL refrigerated cabinet, 1 door. Remote refrigeration unit, 5 heavy duty climatic class and R452a refrigerant gas. Equipment: 3 650x588 mm plastic coated shelves, lock with key. Temperature range -2°+8°C; ventilated refrigeration. The sturdy moulded slides, attached to the sides of the chamber, allow rapid repositioning of the XL shelves into the 7 available levels, providing +10% extra storage space for ingredients and semi-finished products. Anti-corrosion treated evaporator, Electric defrost. 75 mm insulation thickness - HFO with high insulation performance and low environmental impact (CFC, HCFC, HFC free). PVC handle and magnetic triple chamber door gasket, easily replaceable. Reversible, self-closing door opening with 105° stop. One-piece structure, interior/exterior AISI 304 stainless steel; outside back, external base and inside technical compartment in galvanised/colaminated steel rounded inner corners for easy cleaning. The reinforced modular base in colaminated steel allows installation on wheels, feet, mobile or masonry plinths. Replaceable refrigerant system FSS - Fast Service System - for quick and easy service. Predisposed for connection to Cosmo remote supervision system and ModBus/RTU Rs485 connection.

Technical data

Gross capacity:	601 lt
Temperature range:	-2°+8°C
Refrigerant unit:	remote
Cooling gas:	R452a
Defrost:	Electric
Valve:	Supplied standard with solenoid
Dimensions:	740×815×2085 mm
Packing dimensions:	835×930×2138 mm
Gross weight:	135 Kg
Voltage:	220-240 V - 50-60 Hz
Total rate:	710 W
Absorbed Current:	3,3 A
Cooling capacity:	448 W*
*:	Evap. -10°C Cond. +55°C

Features

Standard equipment:	3 griglie plastificate 650x588 mm Serratura con chiave
Control:	Electronic, display flush with the panel
Doors:	1 door, self-closing with a 105° stop, right hinged
Door gasket:	Magnetic, triple chamber and easily replaceable
Insulation:	75 mm thickness - CFC/HCFC free
Exterior/interior finishing:	Exterior and interior AISI 304 stainless steel. Back, base and internal technical compartment in galvanized/colaminated steel.
Inner corners:	Rounded for easy cleaning and ensuring maximum hygiene
Handle:	In PVC
Racks and slides:	Guide in tecnopolimero ad alta resistenza fissate ai fianchi della camera
Feets:	AISI 304 stainless steel adjustable h 100/150 mm
Cosmo:	Predisposed for Cosmo Hub connection

Accessories and variants

Alimentazione frequenza 60Hz	4 Swivel and brake castors h 128 mm
Other special voltage	1 door LED lighting
Half doors Smart	Plastic coated shelf 650x588 mm
Frame for fixed masonry plinth	Serial interface, RS485 cable
Remote condensing unit EMT6165GK	Cosmo cable connection kit
Foot pedal kit	Cosmo wifi connection kit

Remote unit technical data

Voltage:	220-240 V - 50 Hz
Cooling gas:	R452A
Gross weight:	17 Kg
Dimensions:	450x300x270 mm
Packing dimensions:	470x330x300 mm
Cooling capacity:	Evap. -10°C Cond. +55°C

COSMO - wi-fi control

Cosmo is The Nice Kitchen's exclusive wi-fi technology that allows Coldline, Modular and Nevo appliances to be connected and monitored from a smartphone. The cabinet, connected with Cosmo kit via cable to a Cosmo hub (MODI, VISION, THAW.PRO, Levtronic, QUBI) or with Cosmo wi-fi kit, can be monitored by the CosmoApp and receive alerts in case of abnormal operation.

Technical draw

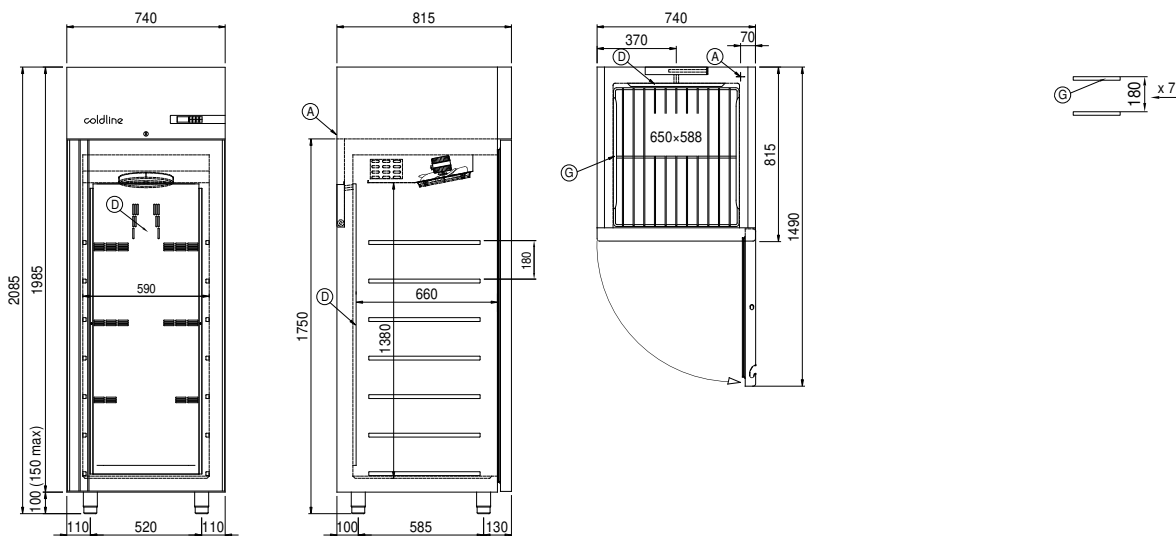

A: Power supply cable outlet

D: Airflow conveyor

G: Racks pitch