

Client _____ Quantity _____
 Project _____ Position _____

Vision NUVO Blast Chiller

Model: W5HS Cod: W64056010011

Vision multifunction blast chiller 5 trays NUVO version, depth 700 mm, temperature range -40°+85°C with humidifier boiler as standard. It is equipped with the functions: blast chilling, blast freezing, manual cycle, thawing, proving, retarded proving, holding, desiccation, chocolate, yoghurt, steam sanitising, steam pasteurisation, low temperature cooking with steam. Plug-In refrigeration system with air condensation with R290 ecological refrigerant gas. Devote™ - Dynamic Evolution Temperature - the innovative system that autonomously recognises the weight, size and temperature of food and automatically shortens the blast chilling or freezing time of hot food without the use of a core probe. Patented NUVO™ technology for cooking food at low temperatures using steam and sequencing blast chilling or blast freezing cycles. 7" touch screen on the door and operating mode with customisable recipes, by time, with core probe or with Devote algorithm. Adjustable ventilation 25-100%, adjustable humidity 45-95%. Blast chilling yield +90/+3°C - 18 Kg; blast freezing yield +90/-18°C - 10 Kg. 5 heavy duty climatic class, hot gas defrost. 60 mm insulation thickness - HFO with high insulation performance and low environmental impact (CFC, HCFC, HFC free). Electronic expansion valve and anti-corrosion painted evaporator. Cushioned door with anti-odour system with Easily replaceable triple chamber magnetic gasket, core probe with screw connector, housing on the port and led lighting. Exterior and interior AISI 304 stainless steel, interior made of "canvas" steel with special highly durable texture. fan unit and condenser cover removable without tools. Equipment: 5 GN1/1-EN60x40 pairs of slides. ModBus/RTU Rs485 connection as standard. Cosmo: wi-fi connection for remote monitoring via Cosmo App. When wired to Coldline counters and cabinets acts as a hub for remote monitoring of connected equipment.

Technical data

| | |
|---------------------|--|
| Top: | Thickness 4 cm. Reinforced in order to place an oven |
| Max capacity: | 6 trays GN |
| Temperature range: | -40°+85°C |
| Ventilation range: | 25% - 100% |
| Humidity range: | 45% - 95% with humidifier |
| Humidifier: | Including |
| Refrigerant unit: | Plug-in |
| Yield +90/+3: | 18 Kg |
| Yield +90/-18: | 10 Kg |
| Climate class: | 5 |
| Cooling gas: | R290 (GWP=3) |
| Refrigerant Charge: | 150g |
| Defrost: | Hot gas |
| Valve: | Electronic expansion valve |
| Dimensions: | 780×759×853 mm |
| Packing dimensions: | 875×915×901 mm |
| Voltage: | 220-240 V - 50 Hz |
| Cooling capacity: | 1349 W* |
| *: | Evap. -10°C Cond. +40°C |

Features

| | |
|------------------------------|---|
| Functions: | Blast chilling, shock freezing, thawing, proving and retarder prover, holding, desiccation, chocolate, yoghurt, steam pasteurisation, low temperature steam cooking, steam sanitizing, manual steam cycle |
| Standard equipment: | 5 slides GN1/1, EN60x40 |
| Control: | 7" touch screen display with USB port |
| Doors: | Cushioned, with anti-odor system |
| Door gasket: | Magnetic, triple chamber and easily replaceable |
| Core probe: | Needle probe with 1 reading point, quick-release and easily replaceable |
| Insulation: | 60 mm thickness - CFC/HCFC free |
| Exterior/interior finishing: | Exterior and interior AISI 304 stainless steel. Internal and external in "linen canvas" steel |
| Inner corners: | Rounded for easy cleaning and ensuring maximum hygiene |
| Handle: | In AISI 304 stainless steel |
| Racks and slides: | Stainless steel AISI 304, quick release |
| Feets: | AISI 304 stainless steel adjustable h 100/150 mm |
| Cosmo: | Wi-Fi remote control system |

Accessories and variants

| | |
|--|---|
| RAL customisable colouring | 4 Swivel and brake castors h 128 mm |
| Sonda al cuore a 3 punti di lettura | Stainless steel shelf GN1/1 |
| Sonda al cuore riscaldata a 1 punto di lettura | Plastic coated shelf GN1/1 |
| Reverse door opening from standard | Stainless steel shelf EN60x40 |
| Alimentazione Monofase 50Hz oppure 60Hz | Plastic coated shelf EN60x40 |
| Alimentazione Trifase 50Hz oppure 60Hz | Pair of type L slides 398 mm GN-EN |
| Alimentazione frequenza 60Hz | Pair of type L slides 398 mm EN |
| Other special voltage | Sanitizing detergent |
| Purity C Quell ST 50 filter cartridge | Touch screen kit for storage device control |
| Lowered foot h 55/70 mm | Cosmo cable connection kit |

COSMO - wi-fi control

Cosmo is The Nice Kitchen's exclusive wi-fi technology that allows VISION blast chillers to be connected, updated and monitored from smartphones. VISION is also a Cosmo hub and allows remote supervision of the Coldline appliances connected to it. From the CosmoApp you can check the operating conditions of each machine and receive alerts in the event of abnormal operation.

Technical draw

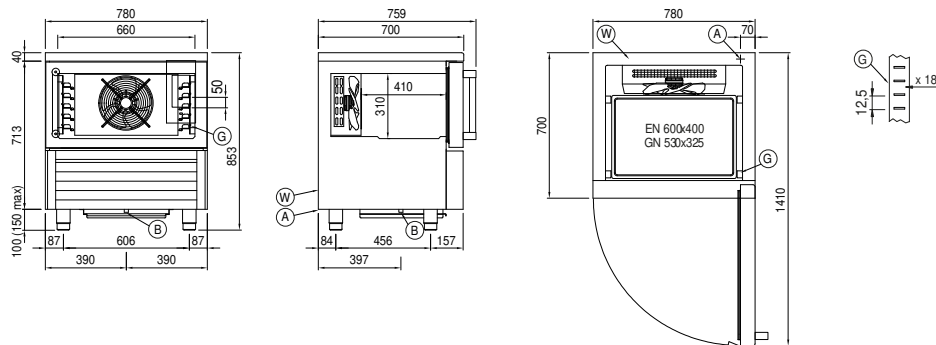

A: Power supply cable outlet

B: Condensation water drain

G: Racks pitch

W: Water mains connection for humidifier - 3/4" female. Unloading not required