

Client _____ Quantity _____
 Project _____ Position _____

Vision NUVO Blast Chiller

Model: W5H

Cod: W64036000011



Vision multifunction blast chiller 5 trays NUVO version, depth 800 mm, temperature range -40°+85°C with humidifier boiler as standard. It is equipped with the functions: blast chilling, blast freezing, manual cycle, thawing, proving, retarded proving, holding, desiccation, chocolate, yoghurt, steam sanitising, steam pasteurisation, low temperature cooking with steam. Plug-In refrigeration system with air condensation with R290 ecological refrigerant gas. Devote™ - Dynamic Evolution Temperature - the innovative system that autonomously recognises the weight, size and temperature of food and automatically shortens the blast chilling or freezing time of hot food without the use of a core probe. Patented NUVO™ technology for cooking food at low temperatures using steam and sequencing blast chilling or blast freezing cycles. 7" touch screen on the door and operating mode with customisable recipes, by time, with core probe or with Devote algorithm. Adjustable ventilation 25-100%, adjustable humidity 45-95%. Blast chilling yield +90/+3°C - 23 Kg; blast freezing yield +90/-18°C - 18 Kg. 5 heavy duty climatic class, hot gas defrost. 60 mm insulation thickness - HFO with high insulation performance and low environmental impact (CFC, HCFC, HFC free). Electronic expansion valve and anti-corrosion painted evaporator. Cushioned door with anti-odour system with Easily replaceable triple chamber magnetic gasket, core probe with screw connector, housing on the port and led lighting. Exterior and interior AISI 304 stainless steel, interior made of "canvas" steel with special highly durable texture. fan unit and condenser cover removable without tools. Equipment: 5 GN1/1-EN60x40 pairs of slides. ModBus/RTU Rs485 connection as standard. Cosmo: wi-fi connection for remote monitoring via Cosmo App. When wired to Coldline counters and cabinets acts as a hub for remote monitoring of connected equipment.

Technical data

Top:	Thickness 4 cm. Reinforced in order to place an oven
Max capacity:	6 trays GN1/1, EN60x40 h 20 mm
Gross capacity:	134 lt
Temperature range:	-40°+85°C
Ventilation range:	25% - 100%
Humidity range:	45% - 95% with humidifier
Humidifier:	Including
Refrigerant unit:	Plug-in
Yield +90/+3:	23 Kg
Yield +90/-18:	18 Kg
Climate class:	5
Cooling gas:	R290 (GWP=3)
Refrigerant Charge:	150g
Defrost:	Hot gas
Valve:	Electronic expansion valve
Dimensions:	780x859x853 mm
Packing dimensions:	875x915x901 mm
Net / gross weight:	120 Kg / 130 Kg
Net / gross volume:	/ 134 lt
Voltage:	220-240 V - 50 Hz
Total rate:	1772 W - 8,8 A
Cooling capacity:	1349 W*
*:	Evap. -10°C Cond. +40°C
Noise:	59,4 dB

Features

Functions:	Blast chilling, shock freezing, thawing, proving and retarder prover, holding, desiccation, chocolate, yoghurt, steam pasteurisation, low temperature steam cooking, steam sanitizing, manual steam cycle
Standard equipment:	5 slides GN1/1, EN60x40
Control:	7" touch screen display with USB port
Doors:	Cushioned, with anti-odor system
Door gasket:	Magnetic, triple chamber and easily replaceable
Core probe:	Needle probe with 1 reading point, quick-release and easily replaceable
Insulation:	60 mm thickness - CFC/HCFC free
Exterior/interior finishing:	Exterior and interior AISI 304 stainless steel. Internal and external in "linen canvas" steel
Inner corners:	Rounded for easy cleaning and ensuring maximum hygiene
Handle:	In AISI 304 stainless steel
Racks and slides:	Stainless steel AISI 304, quick release
Feets:	AISI 304 stainless steel adjustable h 100/150 mm
Cosmo:	Wi-Fi remote control system

In order to constantly offer the best possible products we reserve the right to make changes on technical specifications without incurring any obligation for equipment previously or subsequently sold.

Accessories and variants

RAL customisable colouring	4 Swivel and brake castors h 128 mm
Sonda al cuore a 3 punti di lettura	Stainless steel shelf GN1/1
Sonda al cuore riscaldata a 1 punto di lettura	Plastic coated shelf GN1/1
Reverse door opening from standard	Stainless steel shelf EN60x40
Alimentazione Monofase 50Hz oppure 60Hz	Plastic coated shelf EN60x40
Alimentazione Trifase 50Hz oppure 60Hz	Pair of type L slides 398 mm GN-EN
Alimentazione frequenza 60Hz	Pair of type L slides 398 mm EN
Other special voltage	Sanitizing detergent
Purity C Quell ST 50 filter cartridge	Touch screen kit for storage device control
Lowered foot h 55/70 mm	Cosmo cable connection kit

COSMO - wi-fi control

Cosmo is The Nice Kitchen's exclusive Wi-Fi technology that allows VISION blast chillers to be connected, updated and monitored from smartphones. VISION is also a Cosmo hub and allows remote supervision of the Coldline appliances connected to it. From the CosmoApp you can check the operating conditions of each machine and receive alerts in the event of abnormal operation.

Technical draw

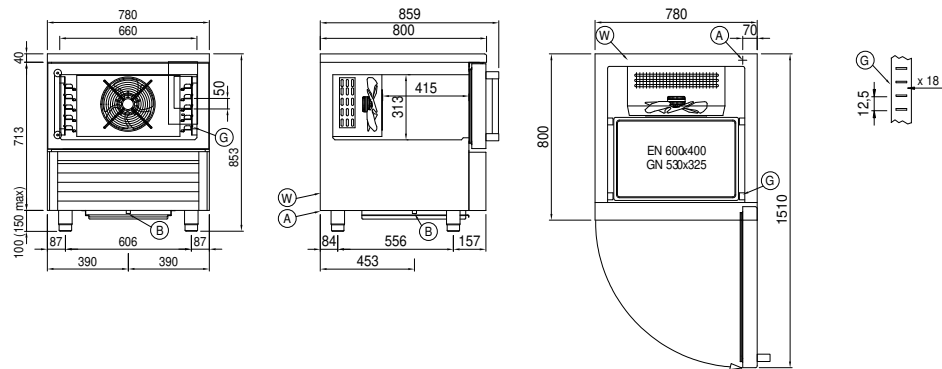

A: Power supply cable outlet

B: Condensation water drain

G: Racks pitch

W: Water mains connection for humidifier - 3/4" female. Unloading not required