

Client _____ Quantity _____
 Project _____ Position _____

Arkis Modi Active Blast Chiller Counter

Model: WHA7AR-760

Cod: W19078012101



Technical data

Top:	Thickness 4 cm. Reinforced in order to place an oven
Gross capacity:	248 lt
Temperature range:	-40°+65°C
Ventilation range:	25% - 100%
Humidifier:	Not available
Refrigerant unit:	remote
Energetic class:	/
Yield +90/+3:	32 Kg
Yield +90/-18:	24 Kg
Cooling gas:	R290 (GWP=3)
Defrost:	Hot gas
Body height:	760 mm
Valve:	Electronic expansion valve
Dimensions:	1400×700×1000 mm
Packing dimensions:	1545×900×998 mm
Net / gross weight:	135 Kg / 145 Kg
Net / gross volume:	/ 248 lt
Voltage:	220-240 V - 50-60 Hz
Total rate:	750 W - 3,62 A
Cooling capacity:	2368 W*
*:	Evap. -10°C Cond. +45°C

Features

Functions:	Blast chilling, shock freezing, thawing, proving, holding, desiccation, chocolate, manual cycle
Standard equipment:	7 slides GN1/1, EN60x40
Control:	4,3" touch screen display with USB port
Door gasket:	Magnetic, triple chamber and easily replaceable
Core probe:	Needle probe with 1 reading point, quick-release and easily replaceable
Insulation:	60 mm thickness - CFC/HCFC free
Exterior/interior finishing:	Exterior and interior AISI 304 stainless steel.
Inner corners:	Rounded for easy cleaning and ensuring maximum hygiene
Handle:	Stainless steel AISI 304, 2 mm thick
Racks and slides:	Stainless steel AISI 304, quick release
Feets:	AISI 304 stainless steel adjustable h 100/150 mm
Cosmo:	Wi-Fi remote control system

In order to constantly offer the best possible products we reserve the right to make changes on technical specifications without incurring any obligation for equipment previously or subsequently sold.

Remote unit technical data

Voltage:	220-240 V - 50 Hz
Cooling gas:	R404-R452a
Gross weight:	25 Kg
Dimensions:	650×650×400 mm
Pipe delivery:	10 mm
Pipe suction:	10 mm
Cooling capacity:	Evap. -10°C Cond. +45°C

COSMO - wi-fi control

Cosmo is The Nice Kitchen's exclusive Wi-Fi technology that allows MODI blast chillers to be connected, updated and monitored from smartphones. MODI is also a Cosmo hub and allows remote supervision of the Coldline appliances connected to it. From the CosmoApp you can check the operating conditions of each machine and receive alerts in the event of abnormal operation.

Technical draw

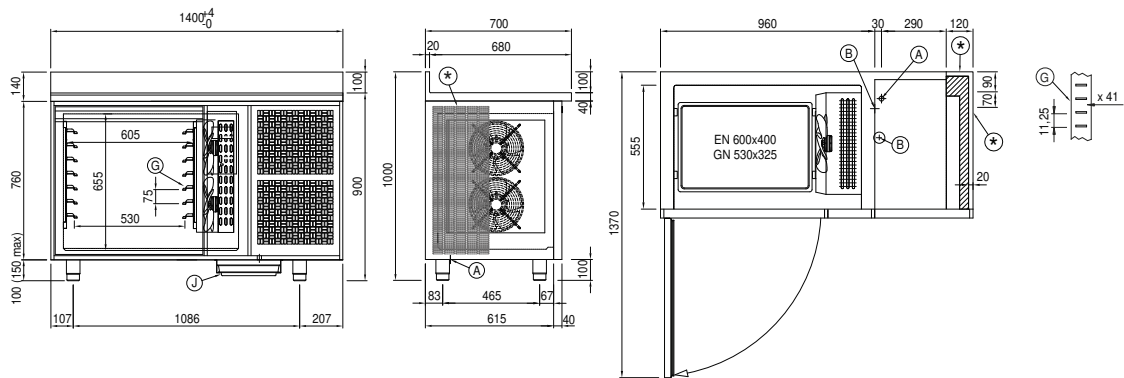

(*) Foratura fianco, schiena e vano tecnico / Sids, back and technical compartment drilling
Bohrung von Seiten-, Rücken- und Technikfach / Perçage latéral, arrière et compartiment technique
Висла lateral, trasera y compartimento técnico / Сверление боковых, задних стенок и технического отсека

- A: Power supply cable outlet B: Condensation water drain G: Racks pitch
- J: Automatic evaporation of condensing water

In order to constantly offer the best possible products we reserve the right to make changes on technical specifications without incurring any obligation for equipment previously or subsequently sold.