

Client _____ Quantity _____

Project _____ Position _____

Saladette Arkis GN counter 4 doors

Model: HP21/1MDR-710

Cod: H80411000211



Technical data

| | |
|---------------------|---------------------------------|
| Top: | With top |
| Gross capacity: | 599 lt |
| Temperature range: | -2°+8°C |
| Refrigerant unit: | remote |
| Cooling gas: | R452a (GWP=2.141) |
| Defrost: | Electric |
| Body height: | 710 mm |
| Valve: | Supplied standard with solenoid |
| Dimensions: | 2050×700×850 mm |
| Packing dimensions: | 2355×800×998 mm |
| Net / gross weight: | 165 Kg / 175 Kg |
| Net / gross volume: | / 599 lt |
| Voltage: | 220-240 V - 50-60 Hz |
| Total rate: | 810W - 3,7A |
| Cooling capacity: | 668 W* |
| *: | Evap. -10°C Cond. +55°C |

Features

| | |
|------------------------------|--|
| Standard equipment: | 4 slides, 4 plastic coated GN1/1 shelves |
| Control: | Electronic, display flush with the panel |
| Doors: | 4 doors with 180° opening |
| Door gasket: | Magnetic, triple chamber and easily replaceable |
| Insulation: | 60 mm thickness - CFC/HCFC free |
| Exterior/interior finishing: | Exterior interior and back in AISI 304 stainless steel. Base in colaminated steel. |
| Inner corners: | Rounded for easy cleaning and ensuring maximum hygiene |
| Handle: | Stainless steel AISI 304, 2 mm thick |
| Racks and slides: | Stainless steel AISI 304 |
| Feets: | AISI 304 stainless steel adjustable h 100/150 mm |
| Cosmo: | Predisposed for Cosmo Hub connection |

Remote unit technical data

| | |
|---------------------|-------------------------|
| Voltage: | 220-240 V - 50 Hz |
| Unit total rate : | 500W - 2,3A |
| Cooling gas: | R452A |
| Gross weight: | 16 Kg |
| Dimensions: | 480×330×295 mm |
| Pipe delivery: | Ø 1/4" |
| Pipe suction: | Ø 3/8" |
| Packing dimensions: | 540×345×310 mm |
| Cooling capacity: | Evap. -10°C Cond. +55°C |

COSMO - wi-fi control

Cosmo is The Nice Kitchen's exclusive Wi-Fi technology that allows Coldline, Modular and Nevo appliances to be connected and monitored from a smartphone. The counter, connected with Cosmo kit via cable to a Cosmo hub (MODI, VISION, THAW.PRO, LEVTRONIC, QUBI) or with Cosmo Wi-Fi kit, can be monitored by the CosmoApp and receive alerts in case of abnormal operation.

Technical draw

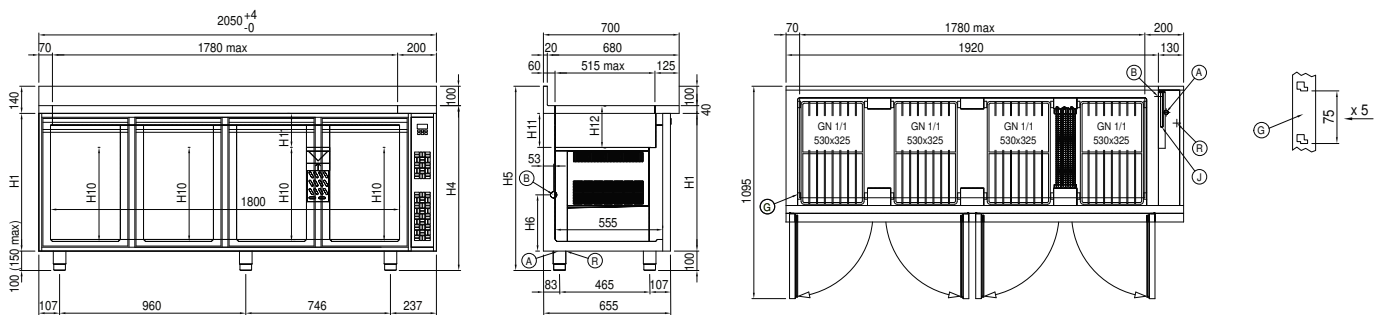

- | | | | | | |
|----|---------------------------|----|---|----|------------------|
| A: | Power supply cable outlet | B: | Condensation water drain | D: | Airflow conveyer |
| G: | Racks pitch | J: | Automatic evaporation of condensing water | R: | Gas output pipes |

In order to constantly offer the best possible products we reserve the right to make changes on technical specifications without incurring any obligation for equipment previously or subsequently sold.