

Client \_\_\_\_\_ Quantity \_\_\_\_\_  
 Project \_\_\_\_\_ Position \_\_\_\_\_

## Smart 700 cabinet

**Model:** A70/1MER

**Cod:** A12071200101



Smart 700 refrigerated cabinet, 1 door. Remote refrigeration unit, 5 heavy duty climatic class and R452a refrigerant gas. Equipment: 3 GN2/1 plastic coated shelves, lock with key. Temperature range -2°+8°C; ventilated refrigeration. Anti-corrosion treated evaporator, Electric defrost. 75 mm insulation thickness - HFO with high insulation performance and low environmental impact (CFC, HCFC, HFC free). PVC handle and magnetic triple chamber door gasket, easily replaceable. Reversible, self-closing door opening with 105° stop. One-piece structure, interior/exterior AISI 304 stainless steel; outside back, external base and inside technical compartment in galvanised/colaminated steel. Rounded inner corners for easy cleaning. The reinforced modular base in colaminated steel allows installation on wheels, feet, mobile or masonry plinths. Replaceable refrigerant system FSS - Fast Service System - for quick and easy service. Predisposed for connection to Cosmo remote supervision system and ModBus/RTU Rs485 connection.

### Technical data

<b>Gross capacity:</b>	601 lt
<b>Temperature range:</b>	-2°+8°C
<b>Refrigerant unit:</b>	remote
<b>Cooling gas:</b>	R452a
<b>Defrost:</b>	Electric
<b>Valve:</b>	Supplied standard with solenoid
<b>Dimensions:</b>	740×815×2085 mm
<b>Packing dimensions:</b>	835×930×2138 mm
<b>Gross weight:</b>	140 Kg
<b>Voltage:</b>	220-240 V - 50-60 Hz
<b>Total rate:</b>	710 W
<b>Absorbed Current:</b>	3,3 A
<b>Cooling capacity:</b>	448 W*
<b>*:</b>	Evap. -10°C Cond. +55°C

### Features

<b>Standard equipment:</b>	3 slides for GN2/1 shelves, 3 plastic coated GN2/1 shelves, lock with key
<b>Control:</b>	Electronic, display flush with the panel
<b>Doors:</b>	1 door, self-closing with a 105° stop, right hinged
<b>Door gasket:</b>	Magnetic, triple chamber and easily replaceable
<b>Insulation:</b>	75 mm thickness - CFC/HCFC free
<b>Exterior/interior finishing:</b>	Exterior and interior AISI 304 stainless steel. Back, base and internal technical compartment in galvanized/colaminated steel.
<b>Inner corners:</b>	Rounded for easy cleaning and ensuring maximum hygiene
<b>Handle:</b>	In PVC
<b>Racks and slides:</b>	Stainless steel AISI 304
<b>Feets:</b>	AISI 304 stainless steel adjustable h 100/150 mm
<b>Cosmo:</b>	Predisposed for Cosmo Hub connection

## Accessories and variants

Alimentazione frequenza 60Hz	1 door LED lighting
Other special voltage	Stainless steel shelf GN2/1
Half doors Smart	Plastic coated shelf GN2/1
Frame for fixed masonry plinth	Pair of type C slides 605 mm
Remote condensing unit EMT6165GK	Serial interface, RS485 cable
Foot pedal kit	Cosmo cable connection kit
4 Swivel and brake castors h 128 mm	Cosmo wifi connection kit

## Remote unit technical data

<b>Voltage:</b>	220-240 V - 50 Hz
<b>Cooling gas:</b>	R452A
<b>Gross weight:</b>	17 Kg
<b>Dimensions:</b>	450×300×270 mm
<b>Packing dimensions:</b>	470×330×300 mm
<b>Cooling capacity:</b>	Evap. -10°C Cond. +55°C

## COSMO - wi-fi control

Cosmo is The Nice Kitchen's exclusive wi-fi technology that allows Coldline, Modular and Nevo appliances to be connected and monitored from a smartphone. The cabinet, connected with Cosmo kit via cable to a Cosmo hub (MODI, VISION, THAW.PRO, Levtronic, QUBI) or with Cosmo wi-fi kit, can be monitored by the CosmoApp and receive alerts in case of abnormal operation.

## Technical draw

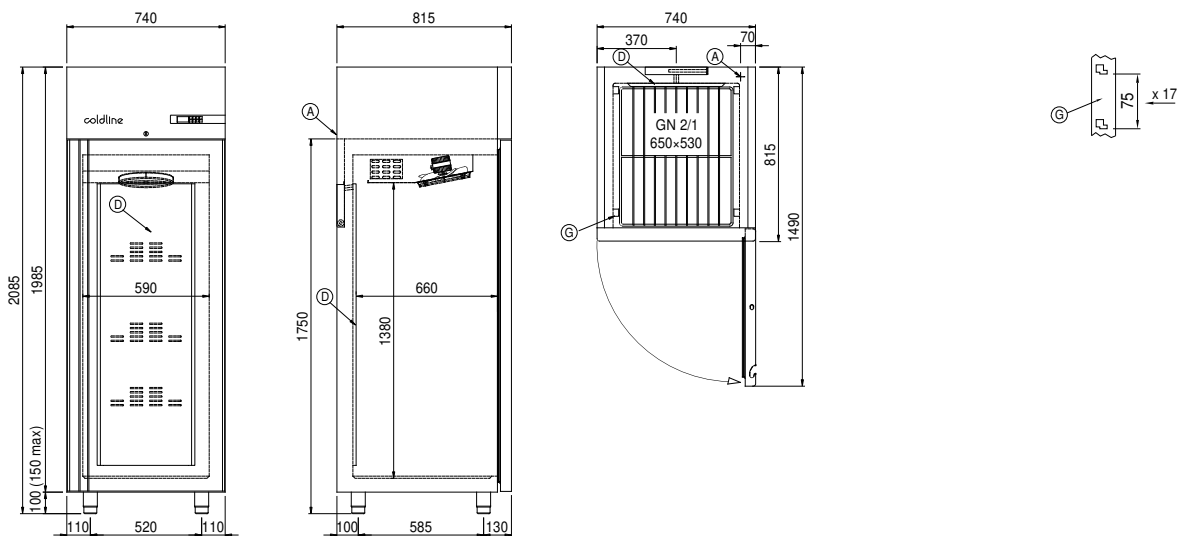

- A:** Power supply cable outlet
- D:** Airflow conveyor
- G:** Racks pitch
- J:** Automatic evaporation of condensing water