

Client _____ Quantity _____
 Project _____ Position _____

Armadio Smart 700 BT

Model: A70/1BER

Cod: A12071600101



Smart 700 refrigerated cabinet, 1 door. Remote refrigeration unit, 5 heavy duty climatic class and R452a refrigerant gas. Equipment: 3 GN2/1 plastic coated shelves, lock with key. Temperature range -18°-22°C; ventilated refrigeration. Anti-corrosion treated evaporator, Electric defrost. 75 mm insulation thickness - HFO with high insulation performance and low environmental impact (CFC, HCFC, HFC free). PVC handle and magnetic triple chamber door gasket, easily replaceable. Reversible, self-closing door opening with 105° stop. One-piece structure, interior/exterior AISI 304 stainless steel; outside back, external base and inside technical compartment in galvanised/colaminated steel. Rounded inner corners for easy cleaning. The reinforced modular base in colaminated steel allows installation on wheels, feet, mobile or masonry plinths. Replaceable refrigerant system FSS - Fast Service System - for quick and easy service. Predisposed for connection to Cosmo remote supervision system and ModBus/RTU Rs485 connection.

Technical data

Gross capacity:	601 lt
Temperature range:	-18°-22°C
Refrigerant unit:	remote
Cooling gas:	R452a
Defrost:	Electric
Valve:	Supplied standard with solenoid
Dimensions:	740×815×2085 mm
Packing dimensions:	835×930×2138 mm
Gross weight:	140 Kg
Voltage:	220-240 V - 50-60 Hz
Total rate:	970 W
Absorbed Current:	4,4 A
Cooling capacity:	646 W*
*:	Evap. -30°C Cond. +55°C

Features

Standard equipment:	3 slides for GN2/1 shelves, 3 plastic coated GN2/1 shelves, lock with key
Control:	Electronic, display flush with the panel
Doors:	1 door, self-closing with a 105° stop, right hinged
Door gasket:	Magnetic, triple chamber and easily replaceable
Insulation:	75 mm thickness - CFC/HCFC free
Exterior/interior finishing:	Exterior and interior AISI 304 stainless steel. Back, base and internal technical compartment in galvanized/colaminated steel.
Inner corners:	Rounded for easy cleaning and ensuring maximum hygiene
Handle:	In PVC
Racks and slides:	Stainless steel AISI 304
Feets:	AISI 304 stainless steel adjustable h 100/150 mm
Cosmo:	Predisposed for Cosmo Hub connection

Accessories and variants

Alimentazione frequenza 60Hz	1 door LED lighting
Other special voltage	Stainless steel shelf GN2/1
Half doors Smart	Plastic coated shelf GN2/1
Frame for fixed masonry plinth	Pair of type C slides 605 mm
Remote condensing unit NT2180GK	Serial interface, RS485 cable
Foot pedal kit	Cosmo cable connection kit
4 Swivel and brake castors h 128 mm	Cosmo wifi connection kit

Remote unit technical data

Voltage:	220-240 V - 50 Hz
Cooling gas:	R452A
Gross weight:	30,2 Kg
Dimensions:	500×330×295 mm
Packing dimensions:	540×345×310 mm
Cooling capacity:	Evap. -30°C Cond. +55°C

COSMO - wi-fi control

Cosmo is The Nice Kitchen's exclusive wi-fi technology that allows Coldline, Modular and Nevo appliances to be connected and monitored from a smartphone. The cabinet, connected with Cosmo kit via cable to a Cosmo hub (MODI, VISION, THAW.PRO, Levtronic, QUBI) or with Cosmo wi-fi kit, can be monitored by the CosmoApp and receive alerts in case of abnormal operation.

Technical draw

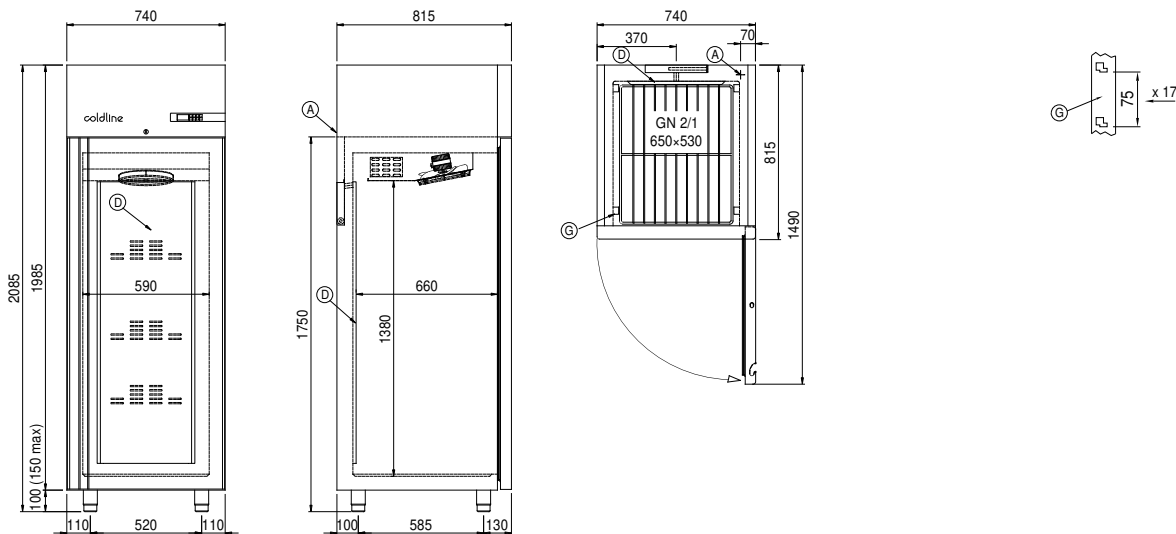

- A:** Power supply cable outlet
- D:** Airflow conveyor
- G:** Racks pitch
- J:** Automatic evaporation of condensing water