

Client _____ Quantity _____
 Project _____ Position _____

Smart 1200 cabinet

Model: A120/2BER

Cod: A12121600201



Smart 1200 refrigerated cabinet, 2 doors. Remote refrigeration unit, 5 heavy duty climatic class and R452a refrigerant gas. Equipment: 3 53x53 cm plastic coated shelves, lock with key. Temperature range -18°-22°C; ventilated refrigeration. Anti-corrosion treated evaporator, Electric defrost. 75 mm insulation thickness - HFO with high insulation performance and low environmental impact (CFC, HCFC, HFC free). PVC handle and magnetic triple chamber door gasket, easily replaceable. Reversible, self-closing door opening with 105° stop. One-piece structure, interior/exterior AISI 304 stainless steel; outside back, external base and inside technical compartment in galvanized/colaminated steel. Rounded inner corners for easy cleaning. The reinforced modular base in colaminated steel allows installation on wheels, feet, mobile or masonry plinths. Replaceable refrigerant system FSS - Fast Service System - for quick and easy service. Predisposed for connection to Cosmo remote supervision system and ModBus/RTU Rs485 connection.

Technical data

Gross capacity:	1155 lt
Temperature range:	-18°-22°C
Refrigerant unit:	remote
Cooling gas:	R452a (GWP=2.141)
Defrost:	Electric
Valve:	Supplied standard with solenoid
Dimensions:	1480×715×2085 mm
Packing dimensions:	1575×930×2144 mm
Net / gross weight:	175 Kg / 201 Kg
Net / gross volume:	733 lt / 1155 lt
Voltage:	220-240 V - 50-60 Hz
Total rate:	1060W - 4,9A
Cooling capacity:	965 W*
*:	Evap. -30°C Cond. +55°C

Features

Standard equipment:	6 slides for 53x53 cm shelves, 6 plastic coated 53x53 cm shelves, lock with key
Control:	Electronic, display flush with the panel
Doors:	2 doors, self-closing with a 105° stop, right hinged
Door gasket:	Magnetic, triple chamber and easily replaceable
Insulation:	75 mm thickness - CFC/HCFC free
Exterior/interior finishing:	Exterior and interior AISI 304 stainless steel. Back, base and internal technical compartment in galvanized/colaminated steel.
Inner corners:	Rounded for easy cleaning and ensuring maximum hygiene
Handle:	In PVC
Racks and slides:	Stainless steel AISI 304
Feets:	AISI 304 stainless steel adjustable h 100/150 mm
Cosmo:	Predisposed for Cosmo Hub connection

Accessories and variants

Alimentazione frequenza 60Hz	2 doors LED lighting
Other special voltage	Plastic coated shelf 53x53
Half doors (4 doors) Smart	Pair of type C slides 505 mm
Frame for fixed masonry plinth	Intermediate shelf connection
Remote condensing unit NT2212GK	Serial interface, RS485 cable
Foot pedal kit	Cosmo cable connection kit
4 Swivel and brake castors h 128 mm	Cosmo wifi connection kit

Remote unit technical data

Voltage:	220-240 V - 50 Hz
Assorbimento Unità Remota:	1130W - 5,2A
Cooling gas:	R452A
Gross weight:	33 Kg
Dimensions:	490x385x345 mm
Pipe delivery:	Ø 3/8"
Pipe suction:	Ø 3/8"
Packing dimensions:	530x440x380 mm
Cooling capacity:	Evap. -30°C Cond. +55°C

COSMO - wi-fi control

Cosmo is The Nice Kitchen's exclusive wi-fi technology that allows Coldline, Modular and Nevo appliances to be connected and monitored from a smartphone. The cabinet, connected with Cosmo kit via cable to a Cosmo hub (MODI, VISION, THAW.PRO, Levtronic, QUBI) or with Cosmo wi-fi kit, can be monitored by the CosmoApp and receive alerts in case of abnormal operation.

Technical draw

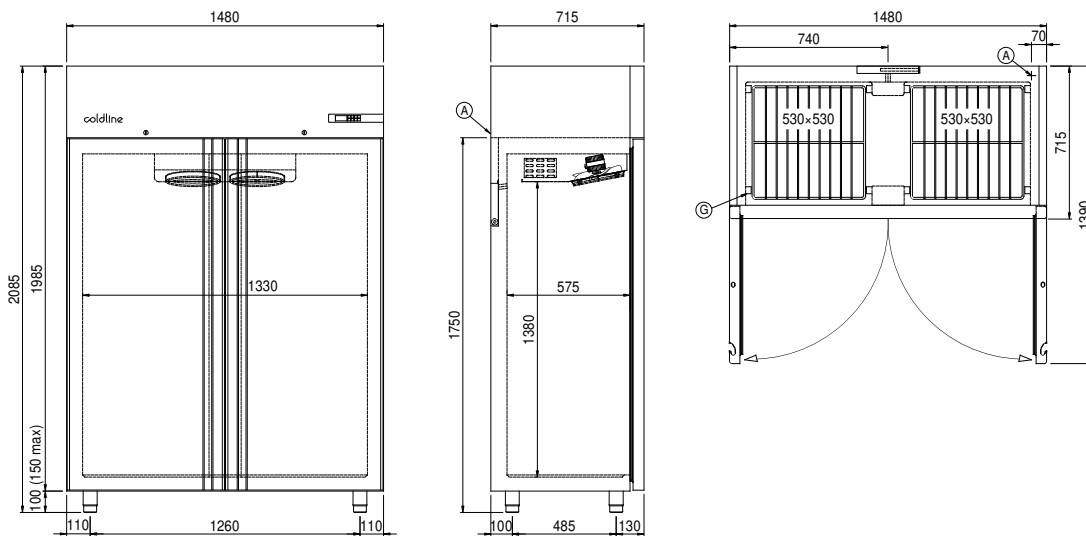

A: Power supply cable outlet

D: Airflow conveyer

G: Racks pitch

J: Automatic evaporation of condensing water