

Client _____ Quantity _____
 Project _____ Position _____

Smart 1400 cabinet

Model: A140/2BER

Cod: A12141600201



Smart 1400 refrigerated cabinet, 2 doors. Remote refrigeration unit, 5 heavy duty climatic class and R452a refrigerant gas. Equipment: 3 GN2/1 plastic coated shelves, lock with key. Temperature range -18°-22°C; ventilated refrigeration. Anti-corrosion treated evaporator, Electric defrost. 75 mm insulation thickness - HFO with high insulation performance and low environmental impact (CFC, HCFC, HFC free). PVC handle and magnetic triple chamber door gasket, easily replaceable. Reversible, self-closing door opening with 105° stop. One-piece structure, interior/exterior AISI 304 stainless steel; outside back, external base and inside technical compartment in galvanized/colaminated steel. Rounded inner corners for easy cleaning. The reinforced modular base in colaminated steel allows installation on wheels, feet, mobile or masonry plinths. Replaceable refrigerant system FSS - Fast Service System - for quick and easy service. Predisposed for connection to Cosmo remote supervision system and ModBus/RTU Rs485 connection.

Technical data

Gross capacity:	1356 lt
Temperature range:	-18°-22°C
Refrigerant unit:	remote
Cooling gas:	R452a (GWP=2.141)
Defrost:	Electric
Valve:	Supplied standard with solenoid
Dimensions:	1480×815×2085 mm
Packing dimensions:	1575×930×2144 mm
Net / gross weight:	205 Kg / 231 Kg
Net / gross volume:	899 lt / 1356 lt
Voltage:	220-240 V - 50-60 Hz
Total rate:	1060W - 4,9A
Cooling capacity:	965 W*
*:	Evap. -30°C Cond. +55°C

Features

Standard equipment:	6 slides for GN2/1 shelves, 6 plastic coated GN2/1 shelves, lock with key
Control:	Electronic, display flush with the panel
Doors:	2 doors, self-closing with a 105° stop, right hinged
Door gasket:	Magnetic, triple chamber and easily replaceable
Insulation:	75 mm thickness - CFC/HCFC free
Exterior/interior finishing:	Exterior and interior AISI 304 stainless steel. Back, base and internal technical compartment in galvanized/colaminated steel.
Inner corners:	Rounded for easy cleaning and ensuring maximum hygiene
Handle:	In PVC
Racks and slides:	Stainless steel AISI 304
Feets:	AISI 304 stainless steel adjustable h 100/150 mm
Cosmo:	Predisposed for Cosmo Hub connection

Accessories and variants

Alimentazione frequenza 60Hz	2 doors LED lighting
Other special voltage	Stainless steel shelf GN2/1
Half doors (4 doors) Smart	Plastic coated shelf GN2/1
Frame for fixed masonry plinth	Pair of type C slides 605 mm
Remote condensing unit NT2212GK	Intermediate shelf connection
Foot pedal kit	Serial interface, RS485 cable
4 Swivel and brake castors h 128 mm	Cosmo cable connection kit

Remote unit technical data

Voltage:	220-240 V - 50 Hz
Assorbimento Unità Remota:	1130W - 5,2A
Cooling gas:	R452A
Gross weight:	33 Kg
Dimensions:	490×385×345 mm
Pipe delivery:	Ø 3/8"
Pipe suction:	Ø 3/8"
Packing dimensions:	530×440×380 mm
Cooling capacity:	Evap. -30°C Cond. +55°C

COSMO - wi-fi control

Cosmo is The Nice Kitchen's exclusive Wi-Fi technology that allows Coldline, Modular and Nevo appliances to be connected and monitored from a smartphone. The cabinet, connected with Cosmo kit via cable to a Cosmo hub (MODI, VISION, THAW.PRO, LEVTRONIC, QUBI) or with Cosmo Wi-Fi kit, can be monitored by the CosmoApp and receive alerts in case of abnormal operation.

Technical draw

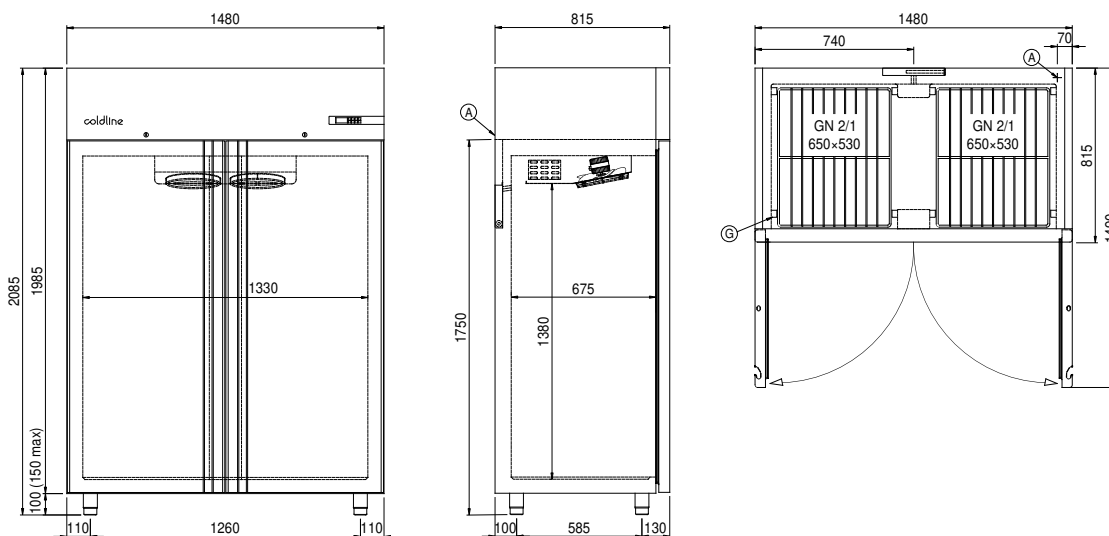

A: Power supply cable outlet

D: Airflow conveyor

G: Racks pitch

J: Automatic evaporation of condensing water

In order to constantly offer the best possible products we reserve the right to make changes on technical specifications without incurring any obligation for equipment previously or subsequently sold.