

Client \_\_\_\_\_ Quantity \_\_\_\_\_  
 Project \_\_\_\_\_ Position \_\_\_\_\_

## Master Combi 700 cabinet

**Model:** A70/2MMR

**Cod:** A14071220201



Master refrigerated Combi 700 cabinet, 2 doors, 2 separate compartments with 2 operating temperatures. Remote refrigeration unit, 5 heavy duty climatic class and R452a refrigerant gas. Equipment: 2+2 GN2/1 plastic coated shelves, lock with key, led lighting. Temperature range compartment A: -2°+8°C; compartment B: -2°+8°C; ventilated refrigeration. Anti-corrosion treated evaporator, Electric defrost. 75 mm insulation thickness - HFO with high insulation performance and low environmental impact (CFC, HCFC, HFC free). AISI 304 stainless steel handle and magnetic triple chamber door gasket, easily replaceable. Reversible, self-closing door opening with 105° stop. One-piece structure, interior/exterior AISI 304 stainless steel; outside back, external base and inside technical compartment in galvanized/colaminated steel. Rounded inner corners for easy cleaning. The reinforced modular base in colaminated steel allows installation on wheels, feet, mobile or masonry plinths. Replaceable refrigerant system FSS - Fast Service System - for quick and easy service. Predisposed for connection to Cosmo remote supervision system and ModBus/RTU Rs485 connection.

### Technical data

<b>Gross capacity:</b>	562 lt
<b>Temperature range:</b>	-2°+8°C/-2°+8°C
<b>Refrigerant unit:</b>	remote
<b>Cooling gas:</b>	R452a
<b>Defrost:</b>	Electric
<b>Valve:</b>	Supplied standard with solenoid
<b>Dimensions:</b>	740×815×2085 mm
<b>Packing dimensions:</b>	835×930×2138 mm
<b>Gross weight:</b>	155 Kg
<b>Voltage:</b>	220-240 V - 50-60 Hz
<b>Total rate:</b>	1270 W
<b>Absorbed Current:</b>	5,8 A
<b>Cooling capacity:</b>	368 W*
<b>Cooling capacity 2:</b>	368 W*
<b>*:</b>	Evap. -10°C Cond. +55°C

### Features

<b>Standard equipment:</b>	4 coppie guida per griglie GN2/1 4 griglie plastificate GN2/1 Serratura con chiave Illuminazione LED
<b>Control:</b>	Electronic, display flush with the panel
<b>Doors:</b>	2 sportelli, autochiudenti con fermo a 105°, cerniere a destra
<b>Door gasket:</b>	Magnetic, triple chamber and easily replaceable
<b>Insulation:</b>	75 mm thickness - CFC/HCFC free
<b>Exterior/interior finishing:</b>	Exterior and interior AISI 304 stainless steel. Back, base and internal technical compartment in galvanized/colaminated steel.
<b>Inner corners:</b>	Rounded for easy cleaning and ensuring maximum hygiene
<b>Handle:</b>	Stainless steel AISI 304, 2 mm thick
<b>Racks and slides:</b>	Stainless steel AISI 304
<b>Feets:</b>	AISI 304 stainless steel adjustable h 100/150 mm
<b>Cosmo:</b>	Predisposed for Cosmo Hub connection

## Accessories and variants

Alimentazione frequenza 60Hz	Stainless steel shelf GN2/1
Other special voltage	Plastic coated shelf GN2/1
Frame for fixed masonry plinth	Pair of type C slides 605 mm
RAL customisable colouring	Stainless steel drawer, h 150 mm 700/1400
Master Marine solutions	Bottles shelf, stainless steel coating for shelf 700/1400
Predisposition for connection to CO2 remote control unit	Serial interface, RS485 cable
Remote condensing unit EMT6144GK	Cosmo cable connection kit
4 Swivel and brake castors h 128 mm	Cosmo wifi connection kit

## Remote unit technical data

<b>Voltage:</b>	220-240 V - 50 Hz
<b>Cooling gas:</b>	R404-R452
<b>Gross weight:</b>	17 Kg
<b>Dimensions:</b>	450×300×270 mm
<b>Packing dimensions:</b>	470×330×300 mm
<b>Cooling capacity:</b>	Evap. -10°C Cond. +55°C

## COSMO - wi-fi control

Cosmo is The Nice Kitchen's exclusive wi-fi technology that allows Coldline, Modular and Nevo appliances to be connected and monitored from a smartphone. The cabinet, connected with Cosmo kit via cable to a Cosmo hub (MODI, VISION, THAW.PRO, Levtronic, QUBI) or with Cosmo wi-fi kit, can be monitored by the CosmoApp and receive alerts in case of abnormal operation.

## Technical draw

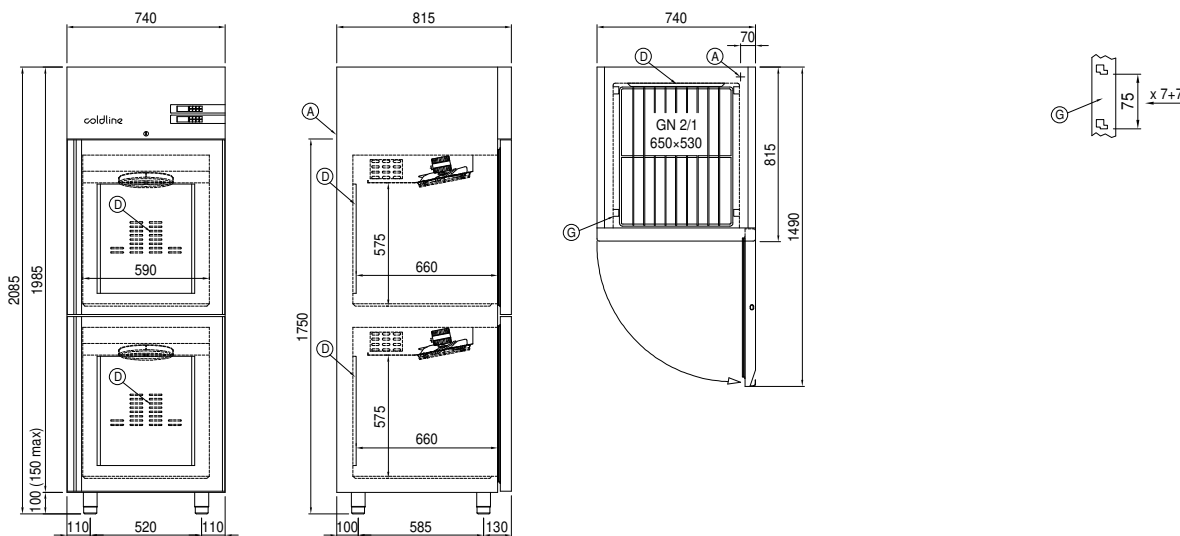

- A:** Power supply cable outlet
- D:** Airflow conveyor
- G:** Racks pitch
- J:** Automatic evaporation of condensing water