

Client \_\_\_\_\_ Quantity \_\_\_\_\_  
 Project \_\_\_\_\_ Position \_\_\_\_\_

## Master 1400 cabinet

**Model:** A140/2M

**Cod:** A14140200201

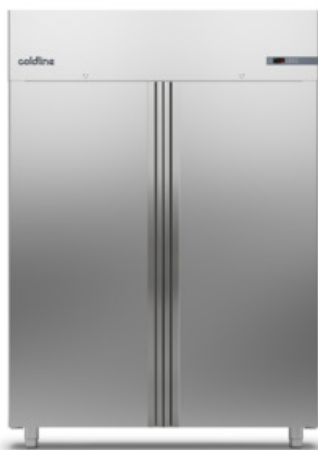

Master 1400 refrigerated cabinet, 2 doors. Plug-in refrigeration unit, B energetic class, 5 heavy duty climatic class and R290 ecological refrigerant gas. Equipment: 3 GN2/1 plastic coated shelves, lock with key, led lighting. Temperature range -2°+8°C; ventilated refrigeration. Anti-corrosion treated evaporator, hot gas defrost. 75 mm insulation thickness - HFO with high insulation performance and low environmental impact (CFC, HCFC, HFC free). AISI 304 stainless steel handle and magnetic triple chamber door gasket, easily replaceable. Reversible, self-closing door opening with 105° stop. One-piece structure, interior/exterior AISI 304 stainless steel; outside back, external base and inside technical compartment in galvanized/colaminated steel. Rounded inner corners for easy cleaning. The reinforced modular base in colaminated steel allows installation on wheels, feet, mobile or masonry plinths. Replaceable refrigerant system FSS - Fast Service System - for quick and easy service. Predisposed for connection to Cosmo remote supervision system and ModBus/RTU Rs485 connection.

### Technical data

<b>Gross capacity:</b>	1356 lt
<b>Temperature range:</b>	-2°+8°C
<b>Refrigerant unit:</b>	Plug-in
<b>Energetic class:</b>	B
<b>Energy efficiency index:</b>	31,6
<b>Annual consumption:</b>	659 kW/h annum
<b>24h consumption:</b>	1,805 kW/h/24h
<b>Climate class:</b>	5
<b>Cooling gas:</b>	R290
<b>Defrost:</b>	Hot gas
<b>Valve:</b>	Supplied standard with solenoid
<b>Dimensions:</b>	1480×815×2085 mm
<b>Packing dimensions:</b>	1575×930×2144 mm
<b>Gross weight:</b>	236 Kg
<b>Voltage:</b>	220-240 V - 50 Hz
<b>Total rate:</b>	260 W
<b>Absorbed Current:</b>	1,2 A
<b>Cooling capacity:</b>	533 W*
<b>*:</b>	Evap. -10°C Cond. +55°C

### Features

<b>Standard equipment:</b>	6 slides for GN2/1 shelves, 6 plastic coated GN2/1 shelves, lock with key, LED lighting
<b>Control:</b>	Electronic, display flush with the panel
<b>Doors:</b>	2 doors, self-closing with a 105° stop, right hinged
<b>Door gasket:</b>	Magnetic, triple chamber and easily replaceable
<b>Insulation:</b>	75 mm thickness - CFC/HCFC free
<b>Exterior/interior finishing:</b>	Exterior and interior AISI 304 stainless steel. Back, base and internal technical compartment in galvanized/colaminated steel.
<b>Inner corners:</b>	Rounded for easy cleaning and ensuring maximum hygiene
<b>Handle:</b>	Stainless steel AISI 304, 2 mm thick
<b>Racks and slides:</b>	Stainless steel AISI 304
<b>Feets:</b>	AISI 304 stainless steel adjustable h 100/150 mm
<b>Cosmo:</b>	Predisposed for Cosmo Hub connection

## Accessories and variants

Alimentazione frequenza 60Hz	4 Swivel and brake castors h 128 mm
Other special voltage	Stainless steel shelf GN2/1
Half doors (4 doors)	Plastic coated shelf GN2/1
Frame for fixed masonry plinth	Pair of type C slides 605 mm
RAL customisable colouring	Stainless steel drawer, h 150 mm 700/1400
Master Marine solutions	Bottles shelf, stainless steel coating for shelf 700/1400
Predisposition for connection to CO2 remote control unit	Intermediate shelf connection
Plug-in water unit	Serial interface, RS485 cable
Foot pedal kit	Cosmo cable connection kit

## COSMO - wi-fi control

Cosmo is The Nice Kitchen's exclusive wi-fi technology that allows Coldline, Modular and Nevo appliances to be connected and monitored from a smartphone. The cabinet, connected with Cosmo kit via cable to a Cosmo hub (MODI, VISION, THAW.PRO, Levtronic, QUBI) or with Cosmo wi-fi kit, can be monitored by the CosmoApp and receive alerts in case of abnormal operation.

## Technical draw

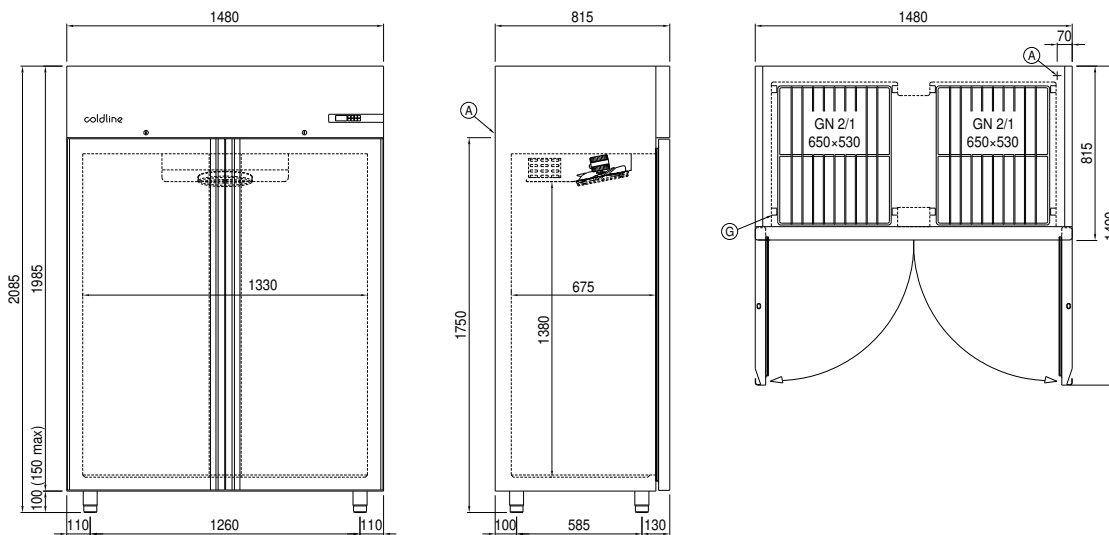

**A:** Power supply cable outlet

**D:** Airflow conveyor

**G:** Racks pitch