

Client _____ Quantity _____
 Project _____ Position _____

Master Combi 1400 cabinet

Model: A140/3MML

Cod: A14140229301

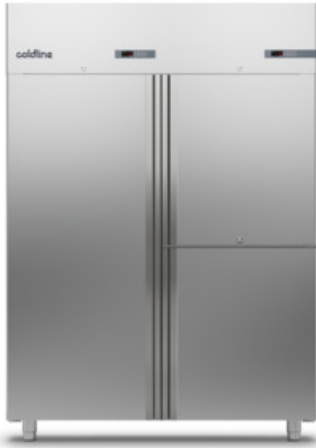

Master refrigerated Combi 1400 cabinet, 3 doors, 2 separate compartments with 2 operating temperatures (L-shaped compartment A and half-door compartment B). Plug-in refrigeration unit, C energetic class, 5 heavy duty climatic class and R290 ecological refrigerant gas. Equipment: 3+2+2 GN2/1 plastic coated shelves, lock with key, led lighting. Temperature range compartment A: -2°+8°C; compartment B: -2°+8°C; ventilated refrigeration. Anti-corrosion treated evaporator, hot gas defrost. 75 mm insulation thickness - HFO with high insulation performance and low environmental impact (CFC, HCFC, HFC free). AISI 304 stainless steel handle and magnetic triple chamber door gasket, easily replaceable. Reversible, self-closing door opening with 105° stop. One-piece structure, interior/exterior AISI 304 stainless steel; outside back, external base and inside technical compartment in galvanised/colaminated steel. Rounded inner corners for easy cleaning. The reinforced modular base in colaminated steel allows installation on wheels, feet, mobile or masonry plinths. Replaceable refrigerant system FSS - Fast Service System - for quick and easy service. Predisposed for connection to Cosmo remote supervision system and ModBus/RTU Rs485 connection.

Technical data

Gross capacity:	1444 lt
Temperature range:	-2°+8°/-2°+8°C
Refrigerant unit:	Plug-in
Energetic class:	C
Energy efficiency index:	45,2
Annual consumption:	885 kW/h annum
24h consumption:	2,425 kW/h/24h
Climate class:	5
Cooling gas:	R290
Defrost:	Hot gas
Valve:	Supplied standard with solenoid
Dimensions:	1480×815×2085 mm
Packing dimensions:	1575×930×2144 mm
Gross weight:	250 Kg
Voltage:	220-240 V - 50 Hz
Total rate:	480 W
Absorbed Current:	2,2 A
Cooling capacity:	533 W*
Cooling capacity 2:	406 W*
*:	Evap. -10°C Cond. +55°C

Features

Standard equipment:	7 slides for GN2/1 shelves, 7 plastic coated GN2/1 shelf, lock with key, LED lighting
Control:	Electronic, display flush with the panel
Doors:	3 doors, self-closing, reversible with 105° stop
Door gasket:	Magnetic, triple chamber and easily replaceable
Insulation:	75 mm thickness - CFC/HCFC free
Exterior/interior finishing:	Exterior and interior AISI 304 stainless steel. Back, base and internal technical compartment in galvanized/colaminated steel.
Inner corners:	Rounded for easy cleaning and ensuring maximum hygiene
Handle:	Stainless steel AISI 304, 2 mm thick
Racks and slides:	Stainless steel AISI 304
Feets:	AISI 304 stainless steel adjustable h 100/150 mm
Cosmo:	Predisposed for Cosmo Hub connection

Accessories and variants

Alimentazione frequenza 60Hz	Stainless steel shelf GN2/1
Other special voltage	Plastic coated shelf GN2/1
Half doors	Pair of type C slides 605 mm
Frame for fixed masonry plinth	Stainless steel drawer, h 150 mm 700/1400
RAL customisable colouring	Bottles shelf, stainless steel coating for shelf 700/1400
Master Marine solutions	Serial interface, RS485 cable
Predisposition for connection to CO2 remote control unit	Cosmo cable connection kit
4 Swivel and brake castors h 128 mm	Cosmo wifi connection kit

COSMO - wi-fi control

Cosmo is The Nice Kitchen's exclusive wi-fi technology that allows Coldline, Modular and Nevo appliances to be connected and monitored from a smartphone. The cabinet, connected with Cosmo kit via cable to a Cosmo hub (MODI, VISION, THAW.PRO, Levtronic, QUBI) or with Cosmo wi-fi kit, can be monitored by the CosmoApp and receive alerts in case of abnormal operation.

Technical draw

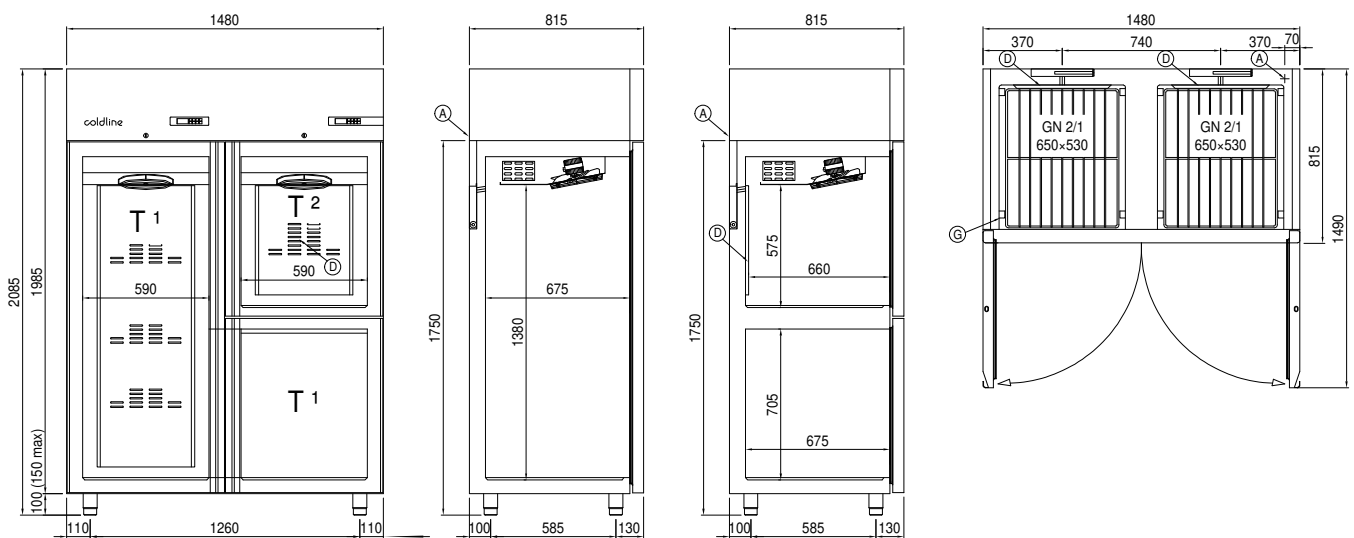

A: Power supply cable outlet

D: Airflow conveyor

G: Racks pitch