

Client _____ Quantity _____
 Project _____ Position _____

Master Fish 1400 cabinet

Model: A140/2PR

Cod: A14141300201

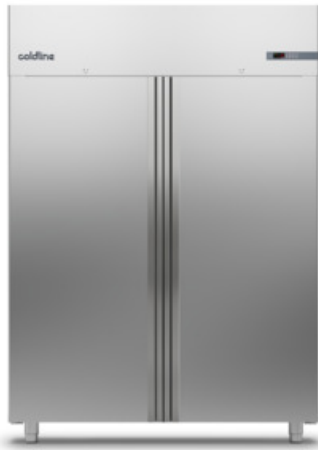

Master refrigerated Fish 1400 cabinet, 3 doors. Remote refrigeration unit, 5 heavy duty climatic class and R452a refrigerant gas. Equipment: 12 GN1/1 ABS fish pans with false bottom, lock with key, led lighting, water drain. Temperature range -6°+40°C; ventilated refrigeration. Anti-corrosion treated evaporator, Electric defrost. 75 mm insulation thickness - HFO with high insulation performance and low environmental impact (CFC, HCFC, HFC free). AISI 304 stainless steel handle and magnetic triple chamber door gasket, easily replaceable. Reversible, self-closing door opening with 105° stop. One-piece structure, interior/exterior AISI 304 stainless steel; outside back, external base and inside technical compartment in galvanised/colaminated steel. Rounded inner corners for easy cleaning. The reinforced modular base in colaminated steel allows installation on wheels, feet, mobile or masonry plinths. Replaceable refrigerant system FSS - Fast Service System - for quick and easy service. Predisposed for connection to Cosmo remote supervision system and ModBus/RTU Rs485 connection.

Technical data

Gross capacity:	1356 lt
Temperature range:	-6°+4°C
Refrigerant unit:	remote
Cooling gas:	R452a
Defrost:	Electric
Valve:	Supplied standard with solenoid
Dimensions:	1480×815×2085 mm
Packing dimensions:	1575×930×2144 mm
Gross weight:	210 Kg
Voltage:	220-240 V - 50-60 Hz
Total rate:	850 W
Absorbed Current:	3,9 A
Cooling capacity:	668 W*
*:	Evap. -10°C Cond. +55°C

Features

Standard equipment:	6 slides for GN2/1 shelves, 12 abs GN1/1 pans, lock with key, LED lighting, water drain
Control:	Electronic, display flush with the panel
Doors:	2 doors, self-closing with a 105° stop, right hinged
Door gasket:	Magnetic, triple chamber and easily replaceable
Insulation:	75 mm thickness - CFC/HCFC free
Exterior/interior finishing:	Exterior and interior AISI 304 stainless steel. Back, base and internal technical compartment in galvanized/colaminated steel.
Inner corners:	Rounded for easy cleaning and ensuring maximum hygiene
Handle:	Stainless steel AISI 304, 2 mm thick
Racks and slides:	Stainless steel AISI 304
Feets:	AISI 304 stainless steel adjustable h 100/150 mm
Cosmo:	Predisposed for Cosmo Hub connection

Accessories and variants

Alimentazione frequenza 60Hz	Stainless steel shelf GN2/1
Other special voltage	Plastic coated shelf GN2/1
Half doors (4 doors)	Pair of type C slides 605 mm
Frame for fixed masonry plinth	Stainless steel drawer, h 150 mm 700/1400
RAL customisable colouring	Bottles shelf, stainless steel coating for shelf 700/1400
Master Marine solutions	Intermediate shelf connection
Predisposition for connection to CO2 remote control unit	Serial interface, RS485 cable
Remote condensing unit NEK6210GK	Cosmo cable connection kit
Foot pedal kit	ABS fish pan GN1/1 with perforated false bottom 2 pieces
4 Swivel and brake castors h 128 mm	R134a valve

Remote unit technical data

Voltage:	220-240 V - 50 Hz
Cooling gas:	R452A
Gross weight:	16 Kg
Dimensions:	480×330×295 mm
Packing dimensions:	540×345×310 mm
Cooling capacity:	Evap. -10°C Cond. +55°C

COSMO - wi-fi control

Cosmo is The Nice Kitchen's exclusive wi-fi technology that allows Coldline, Modular and Nevo appliances to be connected and monitored from a smartphone. The cabinet, connected with Cosmo kit via cable to a Cosmo hub (MODI, VISION, THAW.PRO, Levtronic, QUBI) or with Cosmo wi-fi kit, can be monitored by the CosmoApp and receive alerts in case of abnormal operation.

Technical draw

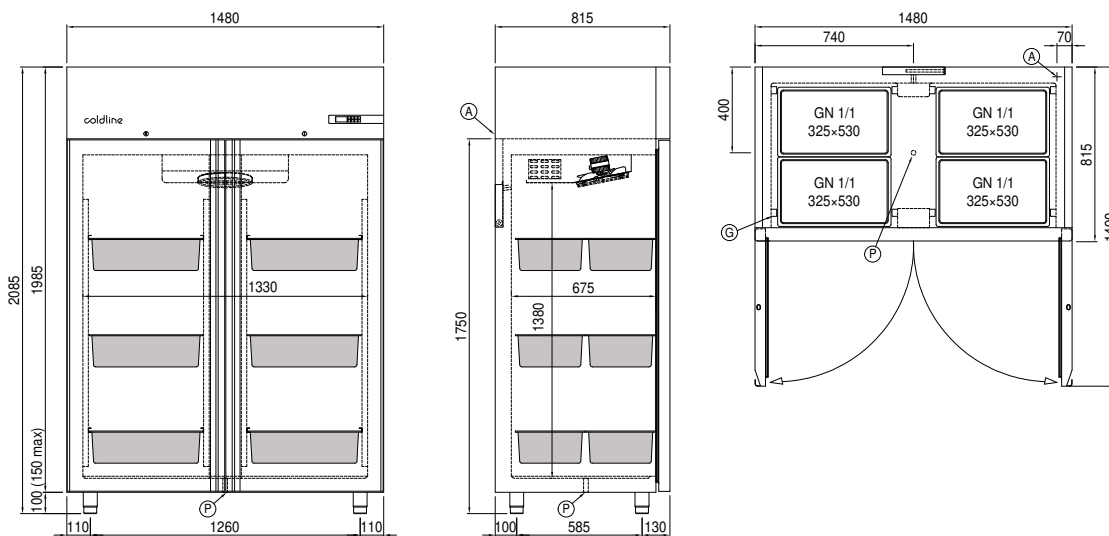

- A:** Power supply cable outlet
- D:** Airflow conveyor
- G:** Racks pitch
- J:** Automatic evaporation of condensing water
- P:** Water drain