

Client \_\_\_\_\_ Quantity \_\_\_\_\_  
 Project \_\_\_\_\_ Position \_\_\_\_\_

## Wind 650 cabinet EN60x40

Model: A80/1T

Cod: A24080700101



Wind 650 refrigerated cabinet, 1 door. Plug-in refrigeration unit, E energetic class, 5 heavy duty climatic class and R290 ecological refrigerant gas. Equipment: 20 pairs of slides for EN60x40 trays, lock with key, led lighting. Temperature range -10°-30°C; ventilated refrigeration with indirect air flow. Anti-corrosion treated evaporator, hot gas defrost. 75 mm insulation thickness - HFO with high insulation performance and low environmental impact (CFC, HCFC, HFC free). AISI 304 stainless steel handle and magnetic triple chamber door gasket, easily replaceable. Reversible, self-closing door opening with 105° stop. One-piece structure, interior/exterior AISI 304 stainless steel; outside back, external base and inside technical compartment in galvanized/colaminated steel. Rounded inner corners for easy cleaning. The reinforced modular base in colaminated steel allows installation on wheels, feet, mobile or masonry plinths. Replaceable refrigerant system FSS - Fast Service System - for quick and easy service. Predisposed for connection to Cosmo remote supervision system and ModBus/RTU Rs485 connection.

### Technical data

Gross capacity:	573 lt
Temperature range:	-10°-30°C
Refrigerant unit:	Plug-in
Energetic class:	E
Energy efficiency index:	81,8
Annual consumption:	2467 kW/h annum
24h consumption:	6,759 kW/h/24h
Climate class:	5
Cooling gas:	R290 (GWP=3)
Refrigerant Charge:	120 g
Defrost:	Hot gas
Valve:	Supplied standard with solenoid
Dimensions:	810x715x2085 mm
Packing dimensions:	905x830x2138 mm
Net / gross weight:	140 Kg / 150 Kg
Net / gross volume:	313 lt / 573 lt
Voltage:	220-240 V - 50 Hz
Total rate:	1180W - 6,2A
Cooling capacity:	561 W
*:	Evap. -30°C Cond. +55°C

### Features

Standard equipment:	20 slides for EN60x40 trays, LED lighting
Control:	Electronic, display flush with the panel
Doors:	1 door, self-closing with a 105° stop, right hinged
Door gasket:	Magnetic, triple chamber and easily replaceable
Insulation:	75 mm thickness - CFC/HCFC free
Exterior/interior finishing:	Exterior and interior AISI 304 stainless steel. Back, base and internal technical compartment in galvanized/colaminated steel.
Inner corners:	Rounded for easy cleaning and ensuring maximum hygiene
Handle:	Stainless steel AISI 304, 2 mm thick
Racks and slides:	Stainless steel AISI 304
Feets:	AISI 304 stainless steel adjustable h 100/150 mm
Cosmo:	Predisposed for Cosmo Hub connection

## Accessories and variants

Half doors	4 Swivel and brake castors h 128 mm
RAL customisable colouring	Aluminium coated backingan EN60x40 h 20 mm
Plug-in water unit	Plastic coated shelf EN60x40
Alimentazione frequenza 60Hz	Pair of type L slides 398 mm EN
Other special voltage	Serial interface, RS485 cable
Foot pedal kit	Cosmo cable connection kit

## COSMO - wi-fi control

Cosmo is The Nice Kitchen's exclusive wi-fi technology that allows Coldline, Modular and Nevo appliances to be connected and monitored from a smartphone. The cabinet, connected with Cosmo kit via cable to a Cosmo hub (MODI, VISION, THAW.PRO, Levtronic, QUBI) or with Cosmo wi-fi kit, can be monitored by the CosmoApp and receive alerts in case of abnormal operation.

## Technical draw

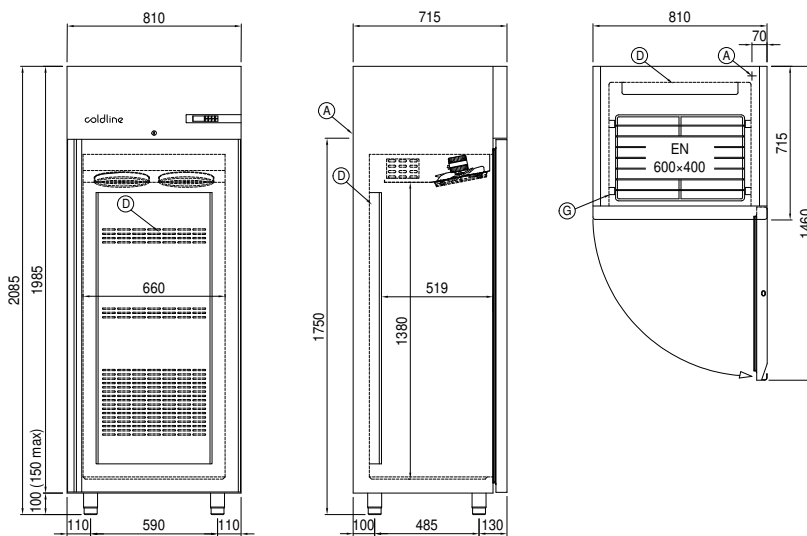

A: Power supply cable outlet

D: Airflow conveyor

G: Racks pitch