

Client \_\_\_\_\_ Quantity \_\_\_\_\_  
 Project \_\_\_\_\_ Position \_\_\_\_\_

## Wind 900 cabinet EN60x80

Model: A90/1T

Cod: A24090700101



Wind 900 refrigerated cabinet, 1 door. Plug-in refrigeration unit, D energetic class, 5 heavy duty climatic class and R290 ecological refrigerant gas. Equipment: 20 pairs of slides for EN60x80 trays, lock with key, led lighting. Temperature range -10°-30°C; ventilated refrigeration with indirect air flow. Anti-corrosion treated evaporator, hot gas defrost. 75 mm insulation thickness - HFO with high insulation performance and low environmental impact (CFC, HCFC, HFC free). AISI 304 stainless steel handle and magnetic triple chamber door gasket, easily replaceable. Reversible, self-closing door opening with 105° stop. One-piece structure, interior/exterior AISI 304 stainless steel; outside back, external base and inside technical compartment in galvanised/colaminated steel. Rounded inner corners for easy cleaning. The reinforced modular base in colaminated steel allows installation on wheels, feet, mobile or masonry plinths. Replaceable refrigerant system FSS - Fast Service System - for quick and easy service. Predisposed for connection to Cosmo remote supervision system and ModBus/RTU Rs485 connection.

### Technical data

|                          |                                 |
|--------------------------|---------------------------------|
| Gross capacity:          | 872 lt                          |
| Temperature range:       | -10°-30°C                       |
| Refrigerant unit:        | Plug-in                         |
| Energetic class:         | D                               |
| Energy efficiency index: | 57,5                            |
| Annual consumption:      | 2623 kW/h annum                 |
| 24h consumption:         | 7,186 kW/h/24h                  |
| Climate class:           | 5                               |
| Cooling gas:             | R290 (GWP=3)                    |
| Refrigerant Charge:      | 120 g                           |
| Defrost:                 | Hot gas                         |
| Valve:                   | Supplied standard with solenoid |
| Dimensions:              | 810x1015x2085 mm                |
| Packing dimensions:      | 905x1130x2140 mm                |
| Net / gross weight:      | 170 Kg / 180 Kg                 |
| Net / gross volume:      | 626 lt / 872 lt                 |
| Voltage:                 | 220-240 V - 50 Hz               |
| Total rate:              | 1180W - 6,2A                    |
| Cooling capacity:        | 561 W*                          |
| *:                       | Evap. -30°C Cond. +55°C         |

### Features

|                              |  |
|------------------------------|--|
| Standard equipment:          | 20 slides for EN60x80 trays, LED lighting  |
| Control:                     | Electronic, display flush with the panel   |
| Doors:                       | 1 door, self-closing with a 105° stop, right hinged  |
| Door gasket:                 | Magnetic, triple chamber and easily replaceable  |
| Insulation:                  | 75 mm thickness - CFC/HCFC free  |
| Exterior/interior finishing: | Exterior and interior AISI 304 stainless steel. Back, base and internal technical compartment in galvanized/colaminated steel. |
| Inner corners:               | Rounded for easy cleaning and ensuring maximum hygiene   |
| Handle:                      | Stainless steel AISI 304, 2 mm thick   |
| Racks and slides:            | Stainless steel AISI 304   |
| Feets:                       | AISI 304 stainless steel adjustable h 100/150 mm   |
| Cosmo:                       | Predisposed for Cosmo Hub connection   |

In order to constantly offer the best possible products we reserve the right to make changes on technical specifications without incurring any obligation for equipment previously or subsequently sold.

## Accessories and variants

|                              |  |
|------------------------------|--|
| Half doors                   | 4 Swivel and brake castors h 128 mm        |
| RAL customisable colouring   | Aluminium coated backingan EN60x40 h 20 mm |
| Plug-in water unit           | Plastic coated shelf EN60x40               |
| Alimentazione frequenza 60Hz | Pair of type L slides 755 mm EN60x80       |
| Other special voltage        | Serial interface, RS485 cable              |
| Foot pedal kit               | Cosmo cable connection kit                 |

## COSMO - wi-fi control

Cosmo is The Nice Kitchen's exclusive Wi-Fi technology that allows Coldline, Modular and Nevo appliances to be connected and monitored from a smartphone. The cabinet, connected with Cosmo kit via cable to a Cosmo hub (MODI, VISION, THAW.PRO, LEVTRONIC, QUBI) or with Cosmo Wi-Fi kit, can be monitored by the CosmoApp and receive alerts in case of abnormal operation.

## Technical draw

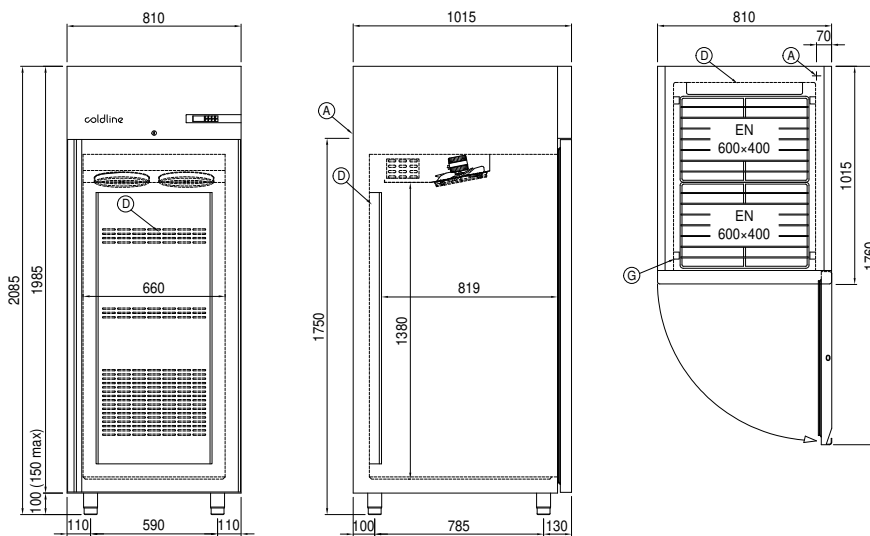

A: Power supply cable outlet

D: Airflow conveyor

G: Racks pitch