

Client \_\_\_\_\_ Quantity \_\_\_\_\_  
 Project \_\_\_\_\_ Position \_\_\_\_\_

## Levtronic 700 cabinet

**Model:** A70/1FHRV

**Cod:** A32071800601



Levtronic 700 retarder prover cabinet, 1 glass door. Remote refrigeration unit, 4 climatic class and R452a refrigerant gas. Equipment: 20 pairs of slides for EN60x40 trays, lock with key, led strip lighting, water drain. Temperature range -6°+40°C and adjustable humidity 45÷95%. Water purification filter. 4.3" touch screen with operating mode with customisable recipes. It is equipped with the functions: retarded proving, manual proving, continuous cycle and storage. Electric defrost. 75 mm insulation thickness - HFO with high insulation performance and low environmental impact (CFC, HCFC, HFC free). Black plastic handle and magnetic triple chamber door gasket, easily replaceable. Reversible, self-closing door opening with 105° stop. One-piece structure, interior/exterior AISI 304 stainless steel; outside back, external base and inside technical compartment in galvanised/colaminated steel. Rounded inner corners for easy cleaning. The reinforced modular base in colaminated steel allows installation on wheels, feet, mobile or masonry plinths. Replaceable refrigerant system FSS - Fast Service System - for quick and easy service. Cosmo: wi-fi connection for remote monitoring via Cosmo App. Hub for connecting Coldline counters and cabinets to Cosmo.

### Technical data

<b>Max capacity:</b>	34 trays EN60x40
<b>Gross capacity:</b>	601 lt
<b>Temperature range:</b>	-6°+40°C
<b>Ventilation range:</b>	25% - 100%
<b>Humidity range:</b>	45% - 95% with humidifier
<b>Humidifier:</b>	Including
<b>Refrigerant unit:</b>	remote
<b>Cooling gas:</b>	R452a
<b>Defrost:</b>	Electric
<b>Valve:</b>	Supplied standard with solenoid
<b>Dimensions:</b>	740×815×2085 mm
<b>Packing dimensions:</b>	835×930×2138 mm
<b>Gross weight:</b>	160 Kg
<b>Voltage:</b>	220-240 V - 50-60 Hz
<b>Total rate:</b>	1250 W

### Features

<b>Functions:</b>	Manual proving, retarder prover, continuous cycle, storage
<b>Standard equipment:</b>	20 slides for EN60x40 trays, lock with key, water drain, LED lighting
<b>Control:</b>	4,3" touch screen display with USB port
<b>Doors:</b>	1 aluminium door, self-closing with 105° latch, right-hand hinges
<b>Door gasket:</b>	Magnetic, triple chamber and easily replaceable
<b>Insulation:</b>	75 mm thickness - CFC/HCFC free
<b>Exterior/interior finishing:</b>	Exterior and interior AISI 304 stainless steel. Back, base and internal technical compartment in galvanized/colaminated steel.
<b>Inner corners:</b>	Rounded for easy cleaning and ensuring maximum hygiene
<b>Handle:</b>	Stainless steel AISI 304, 2 mm thick
<b>Racks and slides:</b>	Stainless steel AISI 304
<b>Feets:</b>	AISI 304 stainless steel adjustable h 100/150 mm
<b>Cosmo:</b>	Wi-Fi remote control system

## Accessories and variants

RAL customisable colouring	Foot pedal kit
Stainless steel evaporator	Purity C Quell ST 50 filter cartridge
Predisposition for connection to CO2 remote control unit	Aluminium coated backingan EN60x40 h 20 mm
Alimentazione frequenza 60Hz	Stainless steel shelf EN60x40
Other special voltage	Plastic coated shelf EN60x40
Remote condensing unit NT2180GK	Pair of type L slides 605 mm

## Remote unit technical data

<b>Voltage:</b>	220-240 V - 50 Hz
<b>Cooling gas:</b>	R452A
<b>Gross weight:</b>	16 Kg
<b>Dimensions:</b>	480x330x295 mm
<b>Packing dimensions:</b>	540x345x310 mm
<b>Cooling capacity:</b>	Evap. -10°C Cond. +55°C

## COSMO - wi-fi control

Cosmo is The Nice Kitchen's exclusive wi-fi technology that allows Levtronic retarder provers to be connected, updated and monitored from smartphones. Levtronic is also a Cosmo hub and allows remote supervision of the Coldline appliances connected to it. From the CosmoApp you can check the operating conditions of each machine and receive alerts in the event of abnormal operation.

## Technical draw

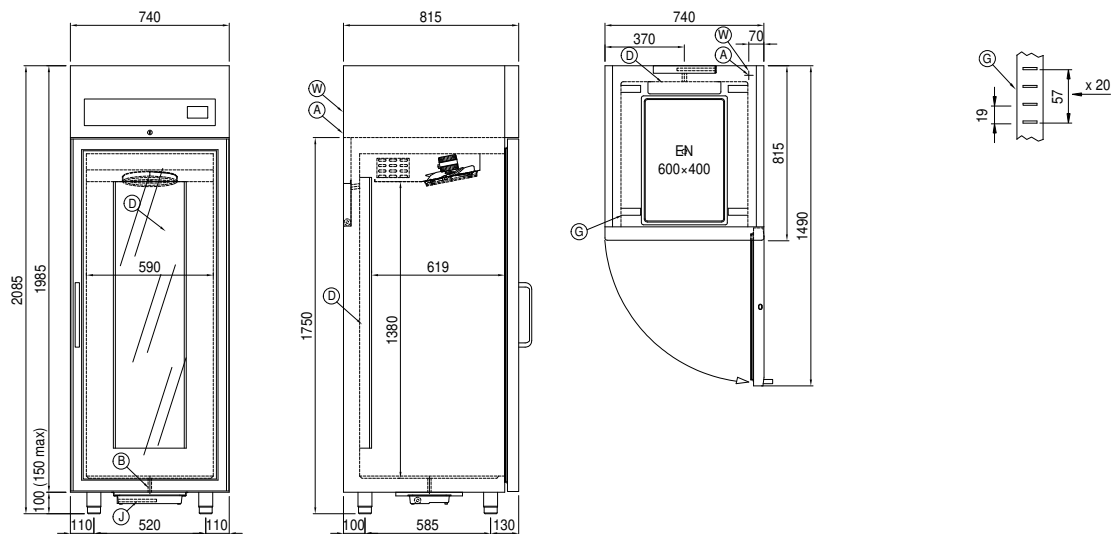

- |                                     |   |   |
|-------------------------------------|---|---|
| <b>A:</b> Power supply cable outlet | <b>B:</b> Condensation water drain                  | <b>D:</b> Airflow conveyor  |
| <b>G:</b> Racks pitch               | <b>J:</b> Automatic evaporation of condensing water | <b>W:</b> Water mains connection for humidifier - 3/4" female. Unloading not required |