

Client _____ Quantity _____
 Project _____ Position _____

Levtronic 650 cabinet

Model: A80/1FHV

Cod: A32080800601



Levtronic 650 retarder prover cabinet, 1 glass door. Plug-in refrigeration unit, E energetic class, 4 climatic class and R290 ecological refrigerant gas. Equipment: 20 pairs of slides for EN60x40 trays, lock with key, led strip lighting, water drain. Temperature range -6°+40°C and adjustable humidity 45÷95%. Water purification filter. 4.3" touch screen with operating mode with customisable recipes. It is equipped with the functions: retarded proving, manual proving, continuous cycle and storage. hot gas defrost. 75 mm insulation thickness - HFO with high insulation performance and low environmental impact (CFC, HCFC, HFC free). Black plastic handle and magnetic triple chamber door gasket, easily replaceable. Reversible, self-closing door opening with 105° stop. One-piece structure, interior/exterior AISI 304 stainless steel; outside back, external base and inside technical compartment in galvanised/colaminated steel. Rounded inner corners for easy cleaning. The reinforced modular base in colaminated steel allows installation on wheels, feet, mobile or masonry plinths. Replaceable refrigerant system FSS - Fast Service System - for quick and easy service. Cosmo: wi-fi connection for remote monitoring via Cosmo App. Hub for connecting Coldline counters and cabinets to Cosmo.

Technical data

Max capacity:	34 trays EN60x40
Gross capacity:	573 lt
Temperature range:	-6°+40°C
Ventilation range:	25% - 100%
Humidity range:	45% - 95% with humidifier
Humidifier:	Including
Refrigerant unit:	Plug-in
Energetic class:	E
Energy efficiency index:	81,9
Annual consumption:	920 kW/h annum
24h consumption:	2,520 kW/h/24h
Climate class:	4
Cooling gas:	R290 (GWP=3)
Refrigerant Charge:	120 g
Defrost:	Hot gas
Valve:	Supplied standard with solenoid
Dimensions:	810×715×2085
Packing dimensions:	905×830×2138 mm
Net / gross weight:	160 Kg / 170 Kg
Net / gross volume:	313 lt / 573 lt
Voltage:	220-240 V - 50 Hz
Total rate:	1360W - 6,2A
Cooling capacity:	668 W*
*:	Evap. -10°C Cond. +55°C

Features

Functions:	Manual proving, retarder prover, continuous cycle, storage
Standard equipment:	20 slides for EN60x40 trays, lock with key, water drain, LED lighting
Control:	4,3" touch screen display with USB port
Doors:	1 aluminium door, self-closing with 105° latch, right-hand hinges
Door gasket:	Magnetic, triple chamber and easily replaceable
Insulation:	75 mm thickness - CFC/HCFC free
Exterior/interior finishing:	Exterior and interior AISI 304 stainless steel. Back, base and internal technical compartment in galvanised/colaminated steel.
Inner corners:	Rounded for easy cleaning and ensuring maximum hygiene
Handle:	Stainless steel AISI 304, 2 mm thick
Racks and slides:	Stainless steel AISI 304
Feets:	AISI 304 stainless steel adjustable h 100/150 mm
Cosmo:	Wi-Fi remote control system

In order to constantly offer the best possible products we reserve the right to make changes on technical specifications without incurring any obligation for equipment previously or subsequently sold.

Accessories and variants

RAL customisable colouring	Purity C Quell ST 50 filter cartridge
Stainless steel evaporator	Aluminium coated backingan EN60x40 h 20 mm
Alimentazione frequenza 60Hz	Stainless steel shelf EN60x40
Other special voltage	Plastic coated shelf EN60x40
Foot pedal kit	Pair of type L slides 398 mm EN

COSMO - wi-fi control

Cosmo is The Nice Kitchen's exclusive Wi-Fi technology that allows Levtronic retarder provers to be connected, updated and monitored from smartphones. Levtronic is also a Cosmo hub and allows remote supervision of the Coldline appliances connected to it. From the CosmoApp you can check the operating conditions of each machine and receive alerts in the event of abnormal operation.

Technical draw

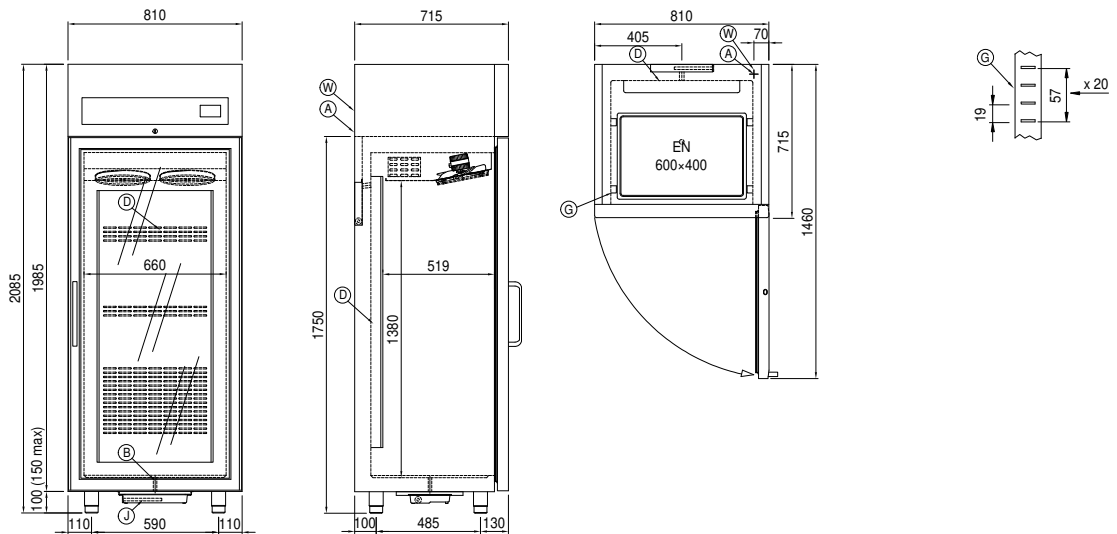

- | | | | | | |
|----|---------------------------|----|---|----|---|
| A: | Power supply cable outlet | B: | Condensation water drain | D: | Airflow conveyer |
| G: | Racks pitch | J: | Automatic evaporation of condensing water | W: | Water mains connection for humidifier - 3/4" female. Unloading not required |

In order to constantly offer the best possible products we reserve the right to make changes on technical specifications without incurring any obligation for equipment previously or subsequently sold.