

Client _____ Quantity _____
 Project _____ Position _____

Vision C60 cabinet

Model: AC60/2T

Cod: A62600700201



Vision AC60 storage cabinet, 2 doors, temperature range -35+15°C. It is equipped with the functions: storage, thawing, chocolate, ice cream. Plug-in refrigeration unit, D energetic class, 5 heavy duty climatic class and R290 ecological refrigerant gas. Hot gas defrost, Adjustable ventilation 50-100% and adjustable humidity 90-40% for the chocolate function. 7" touch screen and operating mode with customisable recipes. Equipment: 20 EN60x80 pairs of slides, led strip lighting, Electronic expansion valve and anti-corrosion painted evaporator. 75 mm insulation thickness - HFO with high insulation performance and low environmental impact (CFC, HCFC, HFC free). AISI 304 stainless steel handles and magnetic triple chamber door gaskets, easily replaceable. Interior/exterior AISI 304 stainless steel; external back, external bottom and internal technical compartment in galvanized/colaminated steel. Cosmo: wi-fi connection for remote monitoring via Cosmo App. When wired to Coldline counters and cabinets acts as a hub for remote monitoring of connected equipment.

Technical data

Max capacity:	30 trays EN60x80 h 20 mm
Gross capacity:	947 lt
Temperature range:	-30°+15°C
Ventilation range:	50% - 100%
Humidity range:	90% - 40% (T°C > +4°C)
Refrigerant unit:	Plug-in
Energetic class:	D
Energy efficiency index:	57,6
Annual consumption:	2806 kW/h annum
24h consumption:	7,687 kW/h/24h
Climate class:	5
Cooling gas:	R290 (GWP=3)
Refrigerant Charge:	150g
Defrost:	Hot gas
Valve:	Supplied standard with solenoid
Dimensions:	810×1096×2215 mm
Packing dimensions:	905×1130×2258 mm
Net / gross weight:	220 Kg / 230 Kg
Net / gross volume:	689 lt / 947 lt
Voltage:	220-240 V - 50 Hz
Total rate:	1410W - 6,5A
Cooling capacity:	965 W*
*:	Evap. -30°C Cond. +55°C

Features

Functions:	Storage, chocolate, thawing, ice cream
Standard equipment:	20 slides for EN60x80 trays, LED lighting
Control:	7" touch screen display with USB port
Doors:	2 doors, self-closing with a 105° stop, right hinged
Door gasket:	Magnetic, triple chamber and easily replaceable
Insulation:	75 mm thickness - CFC/HCFC free
Exterior/interior finishing:	Exterior and interior AISI 304 stainless steel. Back, base and internal technical compartment in galvanized/colaminated steel.
Inner corners:	Rounded for easy cleaning and ensuring maximum hygiene
Handle:	In AISI 304 stainless steel
Racks and slides:	Stainless steel AISI 304
Feets:	AISI 304 stainless steel adjustable h 100/150 mm
Cosmo:	Wi-Fi remote control system

In order to constantly offer the best possible products we reserve the right to make changes on technical specifications without incurring any obligation for equipment previously or subsequently sold.

Accessories and variants

RAL customisable colouring	Aluminium coated backingan EN60x40 h 20 mm
Plug-in water unit	Stainless steel shelf EN60x40
Alimentazione frequenza 60Hz	Plastic coated shelf EN60x40
Other special voltage	Pair of type L slides 755 mm EN60x80
4 Swivel and brake castors h 128 mm	Serial interface, RS485 cable

COSMO - wi-fi control

Cosmo is The Nice Kitchen's exclusive Wi-Fi technology that allows VISION storage units to be connected, updated and monitored from smartphones. VISION is also a Cosmo hub and allows remote supervision of the Coldline appliances connected to it. From the CosmoApp you can check the operating conditions of each machine and receive alerts in the event of abnormal operation.

Technical draw

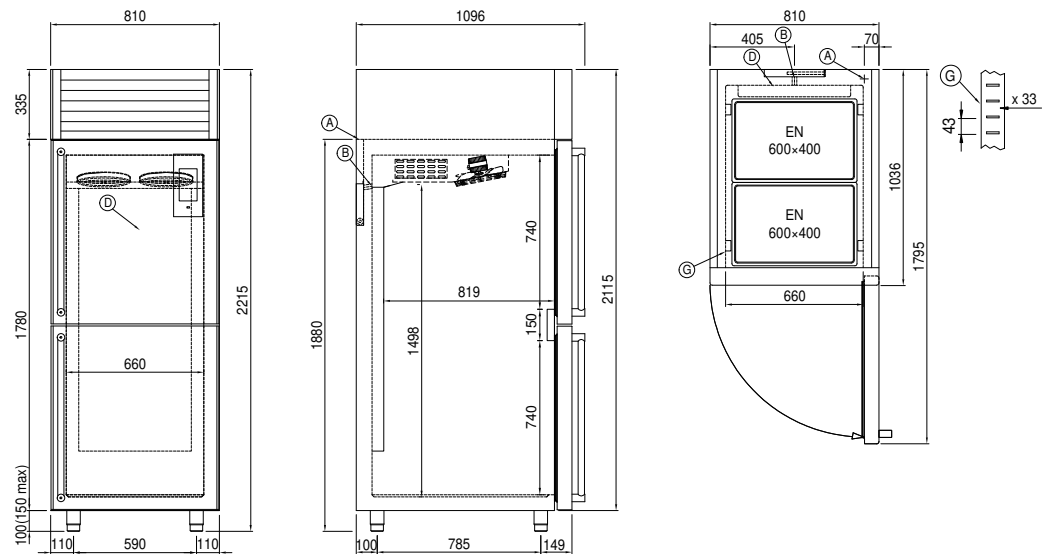

A: Power supply cable outlet

D: Airflow conveyor

G: Racks pitch