

Client _____ Quantity _____
 Project _____ Position _____

Master 600 counter 2 doors

Model: TA13/1MQR-710

Cod: T12212000201

Master 600 refrigerated counter 1 door, counter body height 710 mm, with top. Remote refrigeration unit, 5 heavy duty climatic class and R452a refrigerant gas. Temperature range -15°-22°C with ventilated refrigeration. Equipment: 2 325x430 mm plastic coated shelves. Each compartment can be configured with 1/2+1/2, 1/3+2/3, 1/3+1/3+1/3 drawers. Anti-corrosion treated evaporator and electric defrosting. 60 mm insulation thickness - HFO with high insulation performance and low environmental impact (CFC, HCFC, HFC free). AISI 304 stainless steel handle and magnetic triple chamber door gasket, easily replaceable. Reversible, self-closing door opening with 105° stop. AISI 304 stainless steel interior/exterior including external back. Rounded inner corners for easy cleaning. The reinforced modular base in colaminated steel allows installation on wheels, feet, mobile or masonry plinths. Replaceable refrigerant system FSS - Fast Service System - for quick and easy service. Prepared for connection to Cosmo - wi-fi remote supervision system - and ModBus/RTU Rs485 connection.



Technical data

| | |
|----------------------------|---------------------------------|
| Top: | With top and splashback |
| Gross capacity: | 229 lt |
| Temperature range: | -2°+8°C |
| Refrigerant unit: | remote |
| Cooling gas: | R452a |
| Defrost: | Electric |
| Body height: | 710 mm |
| Valve: | Supplied standard with solenoid |
| Dimensions: | 1090×600×950 mm |
| Packing dimensions: | 1395×800×998 mm |
| Gross weight: | 100 Kg |
| Voltage: | 220-240 V - 50-60 Hz |
| Total rate: | 810 W |
| Absorbed Current: | 3,7 A |
| Cooling capacity: | 519 W* |

Features

| | |
|-------------------------------------|--|
| Standard equipment: | 2 slides, 2 plastic coated 325x430 mm shelves |
| Control: | Electronic, display flush with the panel |
| Doors: | 2 doors, self-closing, reversible with 105° stop |
| Door gasket: | Magnetic, triple chamber and easily replaceable |
| Insulation: | 60 mm thickness - CFC/HCFC free |
| Exterior/interior finishing: | Exterior interior and back in AISI 304 stainless steel. Base in colaminated steel. |
| Inner corners: | Rounded for easy cleaning and ensuring maximum hygiene |
| Handle: | Stainless steel AISI 304, 2 mm thick |
| Racks and slides: | Stainless steel AISI 304 |
| Feets: | AISI 304 stainless steel adjustable h 100/150 mm |
| Cosmo: | Predisposed for Cosmo Hub connection |

Accessories and variants

| | |
|--|---|
| Drawers 1/2 | Other special voltage |
| Drawers 1/3 | Internal hygiene H3 |
| Drawers 1/3 + 2/3 | Granite flat worktop |
| Special counter body heights 650 mm | Granite worktop with splashback |
| Special counter body heights 700 mm | Remote condensing unit EMT6165GK |
| Special counter body heights 750 mm | Adjustable feet h 145/195 mm |
| Technical compartment on the left | 4 Swivel and brake castors h 128 mm |
| Common technical compartment | Brackets for GN pans for drawer |
| Counters without a technical compartment | GN1/2 container + lids kit for drawer, h 150 mm |
| Lock with key for drawer 1/2 | GN1/3 container + lids kit for drawer, h 150 mm |
| Lock with key for drawer 1/3 | Plastic coated shelf 325x430 |
| Lock with key for drawer 1/3 + 2/3 | Pair of type C slides 405 mm |
| Glass door | Serial interface, RS485 cable |
| LED lighting | Cosmo cable connection kit |
| RAL customisable colouring | Cosmo wifi connection kit |
| Predisposition for connection to CO2 remote control unit | Removable plinth CQ 2DR h 100 mm |
| Alimentazione frequenza 60Hz | Removable plinth CQ 2DR h 150 mm |

Remote unit technical data

| | |
|----------------------------|-------------------------|
| Voltage: | 220-240V - 50 Hz |
| Cooling gas: | R452A |
| Gross weight: | 17 Kg |
| Dimensions: | 450x300x270 mm |
| Packing dimensions: | 470x330x300 mm |
| Cooling capacity: | Evap. -10°C Cond. +55°C |

COSMO - wi-fi control

Cosmo is The Nice Kitchen's exclusive wi-fi technology that allows Coldline, Modular and Nevo appliances to be connected and monitored from a smartphone. The counter, connected with Cosmo kit via cable to a Cosmo hub (MODI, VISION, THAW.PRO, Levtronic, QUBI) or with Cosmo wi-fi kit, can be monitored by the CosmoApp and receive alerts in case of abnormal operation.

Technical draw

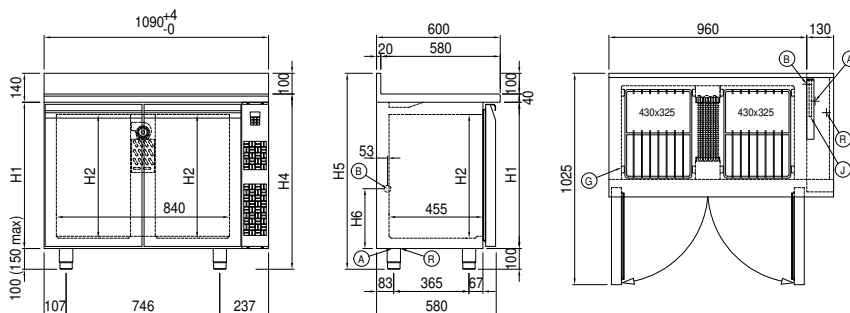

- | | | |
|---|------------------------------------|-----------------------|
| A: Power supply cable outlet | B: Condensation water drain | G: Racks pitch |
| J: Automatic evaporation of condensing water | R: Gas output pipes | |