

Client _____ Quantity _____
 Project _____ Position _____

Pizza EN60x40 counter 3 doors with drawers

Model: TZ17/1MC-710

Cod: T40803000261

Pizza refrigerated counter 3 doors with 1 drawers, counter body height 710 mm, with Rosa Beta granite top. Plug-in refrigeration unit, B energetic class, 5 heavy duty climatic class and R290 ecological refrigerant gas. Temperature range -2°+8°C with ventilated refrigeration. Equipment: 12 pairs of slides for EN60x40 trays. Each compartment can be configured with refrigerated and neutral drawers. Anti-corrosion treated evaporator and hot gas defrosting. 60 mm insulation thickness - HFO with high insulation performance and low environmental impact (CFC, HCFC, HFC free). AISI 304 stainless steel handle and magnetic triple chamber door gasket, easily replaceable. Reversible, self-closing door opening with 105° stop. AISI 304 stainless steel interior/exterior including external back. Rounded inner corners for easy cleaning. The reinforced modular base in colaminated steel allows installation on wheels, feet, mobile or masonry plinths. Replaceable refrigerant system FSS - Fast Service System - for quick and easy service. Prepared for connection to Cosmo - wi-fi remote supervision system - and ModBus/RTU Rs485 connection.



Technical data

| | |
|---------------------------------|---------------------------------|
| Top: | With top and splashback |
| Gross capacity: | 607 lt |
| Temperature range: | -2°+8°C |
| Refrigerant unit: | Plug-in |
| Energetic class: | B |
| Energy efficiency index: | 31 |
| Annual consumption: | 858 kW/h annum |
| 24h consumption: | 2,351 kW/h/24h |
| Climate class: | 5 |
| Cooling gas: | R290 |
| Defrost: | Hot gas |
| Body height: | 710 mm |
| Valve: | Supplied standard with solenoid |
| Dimensions: | 2560×800×1040 mm |
| Packing dimensions: | 2655×900×998 mm |
| Gross weight: | 290 Kg |
| Voltage: | 220-240 V - 50 Hz |
| Total rate: | 250 W |
| Absorbed Current: | 1,15 A |
| Cooling capacity: | 406 W* |
| *: | Evap. -10°C Cond. +55°C |

Features

| | |
|-------------------------------------|--|
| Standard equipment: | 12 slides EN60x40 |
| Control: | Electronic, display flush with the panel |
| Doors: | 3 doors, self-closing, reversible with 105° stop |
| Door gasket: | Magnetic, triple chamber and easily replaceable |
| Insulation: | 60 mm thickness - CFC/HCFC free |
| Exterior/interior finishing: | Exterior and interior AISI 304 stainless steel. |
| Inner corners: | Rounded for easy cleaning and ensuring maximum hygiene |
| Handle: | Stainless steel AISI 304, 2 mm thick |
| Racks and slides: | Stainless steel AISI 304 |
| Feets: | AISI 304 stainless steel adjustable h 100/150 mm |
| Cosmo: | Predisposed for Cosmo Hub connection |

Accessories and variants

| | |
|------------------------------------|---|
| Drawers 1/2 | 6 Swivel and brake castors h 128 mm |
| Drawers 1/3 | Frame fitted with telescopic EN60x40 slides |
| Drawers 1/3 + 2/3 | EN60x40 Pizza container h 60 mm |
| Lock with key for drawer 1/2 | Aluminium coated backingan EN60x40 h 20 mm |
| Lock with key for drawer 1/3 | Pair of type L slides 605 mm |
| Lock with key for drawer 1/3 + 2/3 | Serial interface, RS485 cable |
| Plug-in water unit | Cosmo cable connection kit |
| Alimentazione frequenza 60Hz | Cosmo wifi connection kit |
| Other special voltage | IP44 schuko socket with cover |
| Adjustable feet h 145/195 mm | Removable plinth EN 3D h 100 mm |

COSMO - wi-fi control

Cosmo is The Nice Kitchen's exclusive wi-fi technology that allows Coldline, Modular and Nevo appliances to be connected and monitored from a smartphone. The counter, connected with Cosmo kit via cable to a Cosmo hub (MODI, VISION, THAW.PRO, Levtronic, QUBI) or with Cosmo wi-fi kit, can be monitored by the CosmoApp and receive alerts in case of abnormal operation.

Technical draw

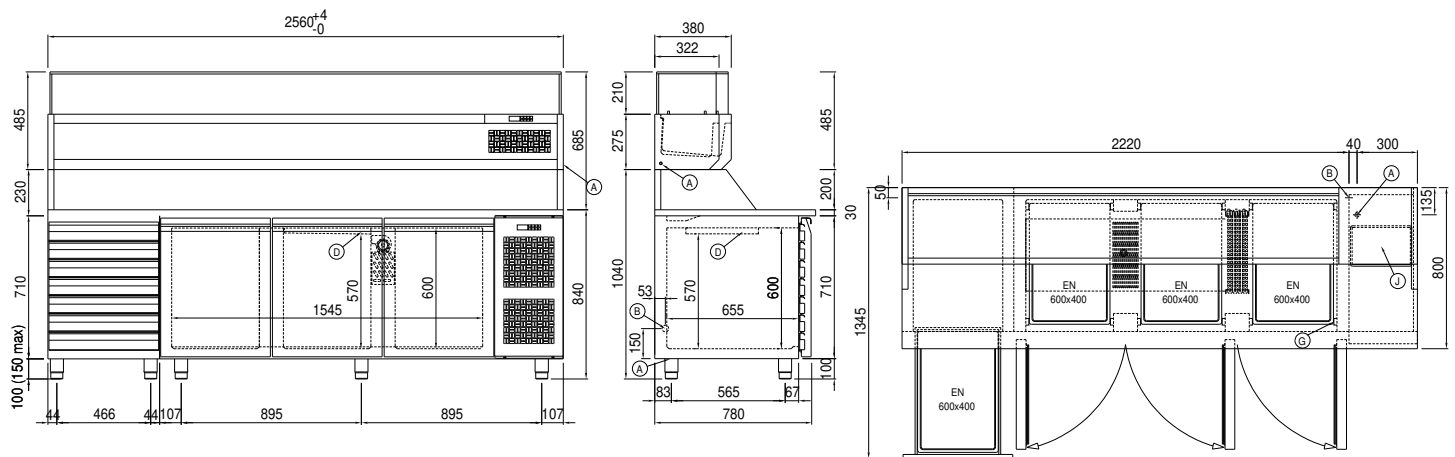

- A:** Power supply cable outlet **B:** Condensation water drain **D:** Airflow conveyor
- G:** Racks pitch **J:** Automatic evaporation of condensing water