

Client _____ Quantity _____
 Project _____ Position _____

Master 350 cabinet

Model: A30/1NV

Cod: A14030100601



Master 350 refrigerated cabinet, 1 door. Plug-in refrigeration unit, C energetic class, 4 climatic class and R290 ecological refrigerant gas. Equipment: 3 53x53 cm plastic coated shelves, lock with key, led strip lighting. Temperature range - 2°+8°C; ventilated refrigeration. Anti-corrosion treated evaporator, off cycle automatic defrost. 75 mm insulation thickness - HFO with high insulation performance and low environmental impact (CFC, HCFC, HFC free). Black plastic handle and magnetic triple chamber door gasket, easily replaceable. Reversible, self-closing door opening with 105° stop. One-piece structure, interior/exterior AISI 304 stainless steel; outside back, external base and inside technical compartment in galvanized/colaminated steel. Rounded inner corners for easy cleaning. The reinforced modular base in colaminated steel allows installation on wheels, feet, mobile or masonry plinths. Replaceable refrigerant system FSS - Fast Service System - for quick and easy service. Predisposed for connection to Cosmo remote supervision system and ModBus/RTU Rs485 connection.

Technical data

Gross capacity:	334 lt
Temperature range:	0°+10°C
Refrigerant unit:	Plug-in
Energetic class:	C
Energy efficiency index:	41,4
Annual consumption:	406 kW/h annum
24h consumption:	1,112 kW/h/24h
Climate class:	4
Cooling gas:	R290 (GWP=3)
Refrigerant Charge:	75g
Defrost:	Off cycle automatic
Valve:	Supplied standard with solenoid
Dimensions:	535x715x2085 mm
Packing dimensions:	835x830x2144 mm
Net / gross weight:	120 Kg / 140 Kg
Net / gross volume:	225 lt / 334 lt
Voltage:	220-240 V - 50 Hz
Total rate:	220W - 1,0A
Cooling capacity:	406 W*
*:	Evap. -10°C Cond. +55°C

Features

Standard equipment:	3 slides for GN1/1 shelves, 3 plastic coated GN1/1 shelves, lock with key, LED lighting
Control:	Electronic, display flush with the panel
Doors:	1 aluminium door, self-closing with 105° latch, right-hand hinges
Door gasket:	Magnetic, triple chamber and easily replaceable
Insulation:	75 mm thickness - CFC/HCFC free
Exterior/interior finishing:	Exterior and interior AISI 304 stainless steel. Back, base and internal technical compartment in galvanized/colaminated steel.
Inner corners:	Rounded for easy cleaning and ensuring maximum hygiene
Handle:	Stainless steel AISI 304, 2 mm thick
Racks and slides:	Stainless steel AISI 304
Feets:	AISI 304 stainless steel adjustable h 100/150 mm
Cosmo:	Predisposed for Cosmo Hub connection

In order to constantly offer the best possible products we reserve the right to make changes on technical specifications without incurring any obligation for equipment previously or subsequently sold.

Accessories and variants

Special rack kit for drawers and shelves	4 Swivel and brake castors h 128 mm
Alimentazione frequenza 60Hz	Stainless steel shelf GN1/1
Other special voltage	Plastic coated shelf GN1/1
Frame for fixed masonry plinth	Pair of type C slides 505 mm
RAL customisable colouring	Stainless steel drawer, h 150 mm 350
Master Marine solutions	Bottles shelf, stainless steel coating for shelf 350
Predisposition for connection to CO2 remote control unit	Serial interface, RS485 cable
Foot pedal kit	Cosmo cable connection kit

COSMO - wi-fi control

Cosmo is The Nice Kitchen's exclusive wi-fi technology that allows Coldline, Modular and Nevo appliances to be connected and monitored from a smartphone. The cabinet, connected with Cosmo kit via cable to a Cosmo hub (MODI, VISION, THAW.PRO, Levtronic, QUBI) or with Cosmo wi-fi kit, can be monitored by the CosmoApp and receive alerts in case of abnormal operation.

Technical draw

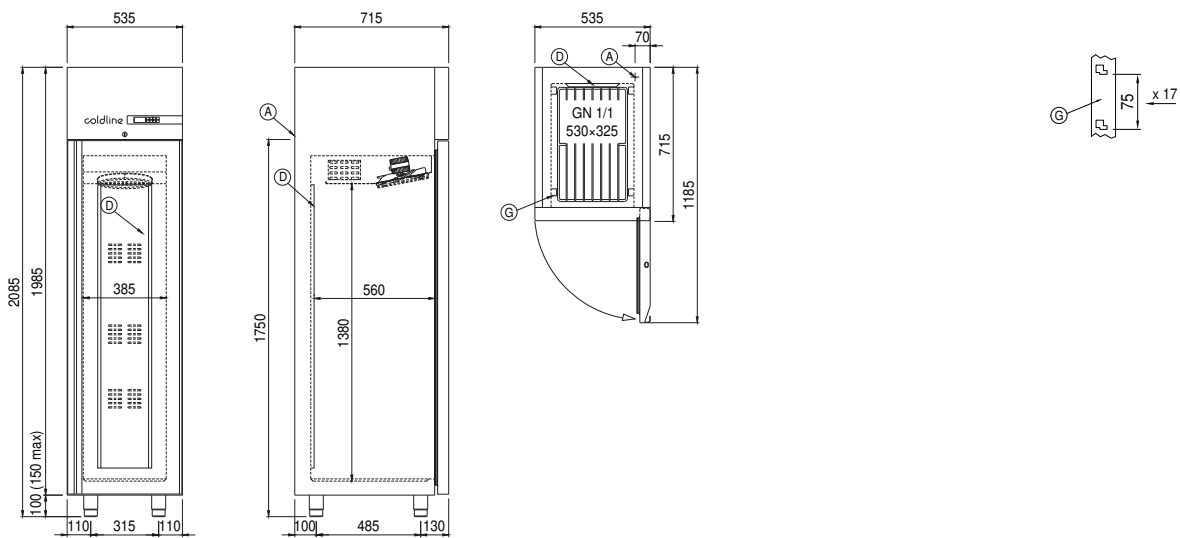

A: Power supply cable outlet

D: Airflow conveyor

G: Racks pitch