

Client \_\_\_\_\_ Quantity \_\_\_\_\_  
 Project \_\_\_\_\_ Position \_\_\_\_\_

## Wind 650 cabinet EN60x40

Model: A80/1MR

Cod: A24081200101



Wind 650 refrigerated cabinet, 1 door. Remote refrigeration unit, 5 heavy duty climatic class and R452a refrigerant gas. Equipment: 20 pairs of slides for EN60x40 trays, lock with key, led lighting. Temperature range -5°+10°C; ventilated refrigeration with indirect air flow. Anti-corrosion treated evaporator, Electric defrost. 75 mm insulation thickness - HFO with high insulation performance and low environmental impact (CFC, HCFC, HFC free). AISI 304 stainless steel handle and magnetic triple chamber door gasket, easily replaceable. Reversible, self-closing door opening with 105° stop. One-piece structure, interior/exterior AISI 304 stainless steel; outside back, external base and inside technical compartment in galvanised/colaminated steel. Rounded inner corners for easy cleaning. The reinforced modular base in colaminated steel allows installation on wheels, feet, mobile or masonry plinths. Replaceable refrigerant system FSS - Fast Service System - for quick and easy service. Predisposed for connection to Cosmo remote supervision system and ModBus/RTU Rs485 connection.

### Technical data

Gross capacity:	573 lt
Temperature range:	-5°+10°C
Refrigerant unit:	remote
Cooling gas:	R452a (GWP=2.141)
Defrost:	Electric
Valve:	Supplied standard with solenoid
Dimensions:	810x715x2085 mm
Packing dimensions:	905x830x2138 mm
Net / gross weight:	120 Kg / 130 Kg
Net / gross volume:	313 lt / 573 lt
Voltage:	220-240 V - 50-60 Hz
Total rate:	850W - 3,9A
Cooling capacity:	668 W*
*:	Evap. -10°C Cond. +55°C

### Features

Standard equipment:	20 slides for EN60x40 trays, LED lighting
Control:	Electronic, display flush with the panel
Doors:	1 door, self-closing with a 105° stop, right hinged
Door gasket:	Magnetic, triple chamber and easily replaceable
Insulation:	75 mm thickness - CFC/HCFC free
Exterior/interior finishing:	Exterior and interior AISI 304 stainless steel. Back, base and internal technical compartment in galvanized/colaminated steel.
Inner corners:	Rounded for easy cleaning and ensuring maximum hygiene
Handle:	Stainless steel AISI 304, 2 mm thick
Racks and slides:	Stainless steel AISI 304
Feets:	AISI 304 stainless steel adjustable h 100/150 mm
Cosmo:	Predisposed for Cosmo Hub connection

## Accessories and variants

Half doors	4 Swivel and brake castors h 128 mm
Glass door for with led lighting	Aluminium coated backingan EN60x40 h 20 mm
RAL customisable colouring	Plastic coated shelf EN60x40
Alimentazione frequenza 60Hz	Pair of type L slides 398 mm EN
Other special voltage	Serial interface, RS485 cable
Remote condensing unit NEK6210GK	Cosmo cable connection kit
Foot pedal kit	Cosmo wifi connection kit

## Remote unit technical data

<b>Voltage:</b>	220-240 V - 50 Hz
<b>Assorbimento Unità Remota:</b>	500W - 2,3A
<b>Cooling gas:</b>	R452A
<b>Gross weight:</b>	16 Kg
<b>Dimensions:</b>	480x330x295 mm
<b>Pipe delivery:</b>	Ø 1/4"
<b>Pipe suction:</b>	Ø 3/8"
<b>Packing dimensions:</b>	540x345x310 mm
<b>Cooling capacity:</b>	Evap. -10°C Cond. +55°C

## COSMO - wi-fi control

Cosmo is The Nice Kitchen's exclusive wi-fi technology that allows Coldline, Modular and Nevo appliances to be connected and monitored from a smartphone. The cabinet, connected with Cosmo kit via cable to a Cosmo hub (MODI, VISION, THAW.PRO, Levtronic, QUBI) or with Cosmo wi-fi kit, can be monitored by the CosmoApp and receive alerts in case of abnormal operation.

## Technical draw

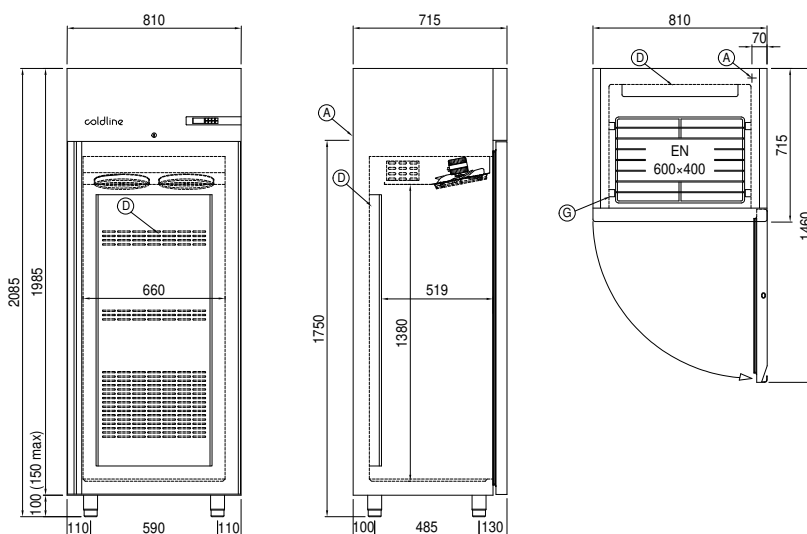

A: Power supply cable outlet

D: Airflow conveyor

G: Racks pitch

J: Automatic evaporation of condensing water