

Client _____ Quantity _____
 Project _____ Position _____

Levtronic 550 cabinet

Model: A55/1FHRV

Cod: A32051800601



Levtronic 550 retarder prover cabinet, 1 glass door. Remote refrigeration unit, 4 climatic class and R452a refrigerant gas. Equipment: 20 pairs of slides for EN60x40 trays, lock with key, led strip lighting, water drain. Temperature range -6°+40°C and adjustable humidity 45÷95%. Water purification filter. 4.3" touch screen with operating mode with customisable recipes. It is equipped with the functions: retarded proving, manual proving, continuous cycle and storage. Electric defrost. 75 mm insulation thickness - HFO with high insulation performance and low environmental impact (CFC, HCFC, HFC free). Black plastic handle and magnetic triple chamber door gasket, easily replaceable. Reversible, self-closing door opening with 105° stop. One-piece structure, interior/exterior AISI 304 stainless steel; outside back, external base and inside technical compartment in galvanised/colaminated steel. Rounded inner corners for easy cleaning. The reinforced modular base in colaminated steel allows installation on wheels, feet, mobile or masonry plinths. Replaceable refrigerant system FSS - Fast Service System - for quick and easy service. Cosmo: wi-fi connection for remote monitoring via Cosmo App. Hub for connecting Coldline counters and cabinets to Cosmo.

Technical data

Max capacity:	34 trays EN60x40
Gross capacity:	489 lt
Temperature range:	-6°+40°C
Ventilation range:	25% - 100%
Humidity range:	45% - 95% with humidifier
Humidifier:	Including
Refrigerant unit:	remote
Cooling gas:	R452a
Defrost:	Electric
Valve:	Supplied standard with solenoid
Dimensions:	630×815×2085 mm
Packing dimensions:	835×930×2138 mm
Gross weight:	135 Kg
Voltage:	220-240 V - 50-60 Hz
Total rate:	1210 W

Features

Functions:	Manual proving, retarder prover, continuous cycle, storage
Standard equipment:	20 slides for EN60x40 trays, lock with key, water drain, LED lighting
Control:	4,3" touch screen display with USB port
Doors:	1 aluminium door, self-closing with 105° latch, right-hand hinges
Door gasket:	Magnetic, triple chamber and easily replaceable
Insulation:	75 mm thickness - CFC/HCFC free
Exterior/interior finishing:	Exterior and interior AISI 304 stainless steel. Back, base and internal technical compartment in galvanized/colaminated steel.
Inner corners:	Rounded for easy cleaning and ensuring maximum hygiene
Handle:	Stainless steel AISI 304, 2 mm thick
Racks and slides:	Stainless steel AISI 304
Feets:	AISI 304 stainless steel adjustable h 100/150 mm
Cosmo:	Wi-Fi remote control system

Accessories and variants

RAL customisable colouring	Foot pedal kit
Stainless steel evaporator	Purity C Quell ST 50 filter cartridge
Predisposition for connection to CO2 remote control unit	Aluminium coated backingan EN60x40 h 20 mm
Alimentazione frequenza 60Hz	Stainless steel shelf EN60x40
Other special voltage	Plastic coated shelf EN60x40
Remote condensing unit EMT6165GK	Pair of type L slides 605 mm

Remote unit technical data

Voltage:	220-240 V - 50 Hz
Cooling gas:	R452A
Gross weight:	17 Kg
Dimensions:	450x300x270 mm
Packing dimensions:	470x330x300 mm
Cooling capacity:	Evap. -10°C Cond. +55°C

COSMO - wi-fi control

Cosmo is The Nice Kitchen's exclusive wi-fi technology that allows Levtronic retarder provers to be connected, updated and monitored from smartphones. Levtronic is also a Cosmo hub and allows remote supervision of the Coldline appliances connected to it. From the CosmoApp you can check the operating conditions of each machine and receive alerts in the event of abnormal operation.

Technical draw

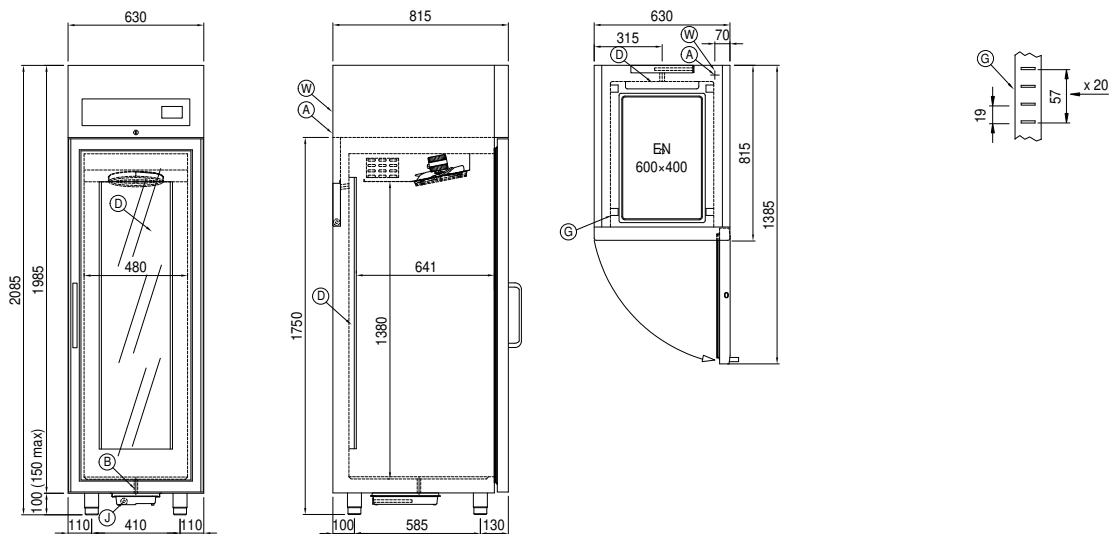

- | | | |
|-------------------------------------|---|---|
| A: Power supply cable outlet | B: Condensation water drain | D: Airflow conveyor |
| G: Racks pitch | J: Automatic evaporation of condensing water | W: Water mains connection for humidifier - 3/4" female. Unloading not required |