

Client _____ Quantity _____
 Project _____ Position _____

Vision F80 cabinet

Model: AF80/2MR

Cod: A64801800201



Vision AF80 retarder prover cabinet, 2 doors, temperature range -6°+40°C. It is equipped with the functions: retarded proving, manual proving, continuous cycle, storage, thawing, chocolate. Remote refrigeration unit, 5 heavy duty climatic class and R452a refrigerant gas. Electric defrost, adjustable ventilation 25-100% and adjustable humidity 45-95%. Water purification filter. 7" touch screen and operating mode with customisable recipes. Equipment: 20 EN60x80 pairs of slides, led strip lighting, water drain, Electronic expansion valve and anti-corrosion painted evaporator. 100 mm insulation thickness - HFO with high insulation performance and low environmental impact (CFC, HCFC, HFC free). AISI 304 stainless steel handles and magnetic triple chamber door gaskets, easily replaceable. Interior/exterior AISI 304 stainless steel; external back, external bottom and internal technical compartment in galvanized/colaminated steel. 2 compressors and 2 independent refrigeration circuits. Cosmo: wi-fi connection for remote monitoring via Cosmo App. When wired to Coldline counters and cabinets acts as a hub for remote monitoring of connected equipment.

Technical data

Max capacity:	40 trays E
Gross capacity:	1057 lt
Temperature range:	-6°+40°C
Ventilation range:	25% - 100%
Humidity range:	45% - 95% with humidifier
Humidifier:	Including
Refrigerant unit:	remote
Cooling gas:	R452a (GWP=2.141)
Defrost:	Electric
Valve:	Supplied standard with solenoid
Dimensions:	900×1138×2465 mm
Packing dimensions:	920×1100×2530 mm
Net / gross weight:	270 Kg / 280 Kg
Net / gross volume:	780 lt / 1057 lt
Voltage:	220-240 V - 50-60 Hz
Total rate:	790W - 3,6A
Cooling capacity:	1336 W*
*:	Evap. -10°C Cond. +55°C

Features

Functions:	Retarder prover, manual proving, continuous cycle, storage, chocolate, thawing, ice cream
Standard equipment:	20 slides for EN60x80 trays, LED lighting
Control:	7" touch screen display with USB port
Doors:	2 doors, self-closing with a 105° stop, right hinged
Door gasket:	Magnetic, triple chamber and easily replaceable
Insulation:	100 mm thickness - CFC/HCFC free
Exterior/interior finishing:	Exterior and interior AISI 304 stainless steel. Back, base and internal technical compartment in galvanized/colaminated steel.
Inner corners:	Rounded for easy cleaning and ensuring maximum hygiene
Handle:	In AISI 304 stainless steel
Racks and slides:	Stainless steel AISI 304
Feets:	AISI 304 stainless steel adjustable h 100/150 mm
Cosmo:	Wi-Fi remote control system

In order to constantly offer the best possible products we reserve the right to make changes on technical specifications without incurring any obligation for equipment previously or subsequently sold.

Accessories and variants

RAL customisable colouring	4 Swivel and brake castors h 128 mm
Alimentazione frequenza 60Hz	Aluminium coated backingan EN60x40 h 20 mm
Other special voltage	Stainless steel shelf EN60x40
Remote condensing unit NEK6210GK	Plastic coated shelf EN60x40
Purity C Quell ST 50 filter cartridge	Pair of type L slides 755 mm EN60x80

Remote unit technical data

Voltage:	220-240 V - 50 Hz
Assorbimento Unità Remota:	500W - 2,3A
Cooling gas:	R452A
Gross weight:	16 Kg
Dimensions:	480x330x295 mm
Pipe delivery:	Ø 1/4"
Pipe suction:	Ø 3/8"
Packing dimensions:	540x345x310 mm
Cooling capacity:	Evap. -10°C Cond. +55°C

COSMO - wi-fi control

Cosmo is The Nice Kitchen's exclusive wi-fi technology that allows VISION retarder provers to be connected, updated and monitored from smartphones. VISION is also a Cosmo hub and allows remote supervision of the Coldline appliances connected to it. From the CosmoApp you can check the operating conditions of each machine and receive alerts in the event of abnormal operation.

Technical draw

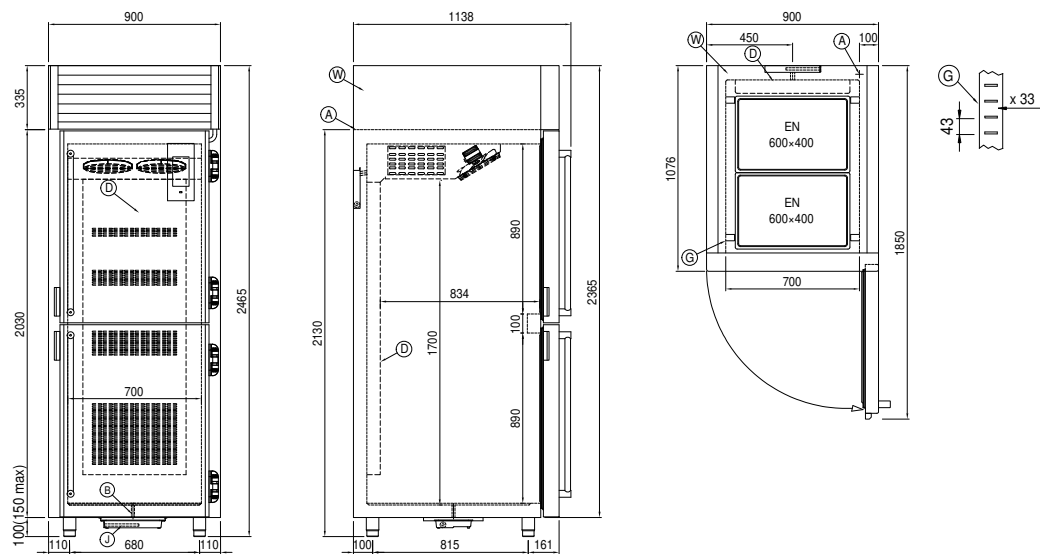

- | | | | | | |
|----|---------------------------|----|-------------------------------------------|----|-----------------------------------------------------------------------------|
| A: | Power supply cable outlet | B: | Condensation water drain | D: | Airflow conveyor |
| G: | Racks pitch | J: | Automatic evaporation of condensing water | W: | Water mains connection for humidifier - 3/4" female. Unloading not required |

In order to constantly offer the best possible products we reserve the right to make changes on technical specifications without incurring any obligation for equipment previously or subsequently sold.