

Client _____ Quantity _____
 Project _____ Position _____

Prep-station GN1/1 counter 2 doors

Model: TV13/1MR-1/3-710

Cod: T10211000221

Prep-Station 700 refrigerated counter 2 doors, counter body height 710 mm, with AISI 304 stainless steel top. Remote refrigeration unit, 5 heavy duty climatic class and R452a refrigerant gas. Temperature range -2°+8°C with ventilated refrigeration. Refrigerated container for GN1/3 bowls with opening lid. Equipment: 2 GN1/1 plastic coated shelves. Each compartment can be configured with 1/2+1/2, 1/3+2/3, 1/3+1/3+1/3 drawers. Anti-corrosion treated evaporator and electric defrosting. 60 mm insulation thickness - HFO with high insulation performance and low environmental impact (CFC, HCFC, HFC free). AISI 304 stainless steel handle and magnetic triple chamber door gasket, easily replaceable. Reversible, self-closing door opening with 105° stop. AISI 304 stainless steel interior/exterior including external back. Rounded inner corners for easy cleaning. The reinforced modular base in colaminated steel allows installation on wheels, feet, mobile or masonry plinths. Replaceable refrigerant system FSS - Fast Service System - for quick and easy service. Prepared for connection to Cosmo - wi-fi remote supervision system - and ModBus/RTU Rs485 connection.



Technical data

Top:	With top
Gross capacity:	280 lt
Temperature range:	-2°+8°C
Refrigerant unit:	remote
Cooling gas:	R452a
Defrost:	Electric
Body height:	710 mm
Valve:	Supplied standard with solenoid
Dimensions:	1090×700×1005 mm
Packing dimensions:	1395×800×998 mm
Gross weight:	125 Kg
Voltage:	220-240 V - 50-60 Hz
Total rate:	810 W
Absorbed Current:	3,7 A
Cooling capacity:	519 W*

Features

Standard equipment:	2 slides, 2 plastic coated GN1/1 shelves
Control:	Electronic, display flush with the panel
Doors:	2 doors, self-closing, reversible with 105° stop
Door gasket:	Magnetic, triple chamber and easily replaceable
Insulation:	60 mm thickness - CFC/HCFC free
Exterior/interior finishing:	Exterior interior and back in AISI 304 stainless steel. Base in colaminated steel.
Inner corners:	Rounded for easy cleaning and ensuring maximum hygiene
Lid hinges:	Made of black plastic
Handle:	Stainless steel AISI 304, 2 mm thick
Racks and slides:	Stainless steel AISI 304
Feets:	AISI 304 stainless steel adjustable h 100/150 mm
Cosmo:	Predisposed for Cosmo Hub connection

Accessories and variants

Drawers 1/2	Remote condensing unit EMT6165GK
Drawers 1/3	Adjustable feet h 145/195 mm
Drawers 1/3 + 2/3	4 Swivel and brake castors h 128 mm
Special counter body heights 700 mm	Brackets for GN pans for drawer
Special counter body heights 750 mm	GN1/2 container + lids kit for drawer, h 150 mm
Technical compartment on the left	GN1/3 container + lids kit for drawer, h 150 mm
Common technical compartment	Stainless steel shelf GN1/1
Special size of technical compartment	Plastic coated shelf GN1/1
Lock with key for drawer 1/2	Pair of type C slides 505 mm
Lock with key for drawer 1/3	Serial interface, RS485 cable
Lock with key for drawer 1/3 + 2/3	Cosmo cable connection kit
LED lighting	Cosmo wifi connection kit
RAL customisable colouring	Prep-Station pans kit GN1/3 remote, 2D
Predisposition for connection to CO2 remote control unit	Removable plinth GN 2DR h 100 mm
Alimentazione frequenza 60Hz	Removable plinth GN 2DR h 150 mm
Other special voltage	R134a valve

Remote unit technical data

Voltage:	220-240V - 50 Hz
Cooling gas:	R452A
Gross weight:	17 Kg
Dimensions:	450x300x270 mm
Packing dimensions:	470x330x300 mm
Cooling capacity:	Evap. -10°C Cond. +55°C

COSMO - wi-fi control

Cosmo is The Nice Kitchen's exclusive wi-fi technology that allows Coldline, Modular and Nevo appliances to be connected and monitored from a smartphone. The counter, connected with Cosmo kit via cable to a Cosmo hub (MODI, VISION, THAW.PRO, Levtronic, QUBI) or with Cosmo wi-fi kit, can be monitored by the CosmoApp and receive alerts in case of abnormal operation.

Technical draw

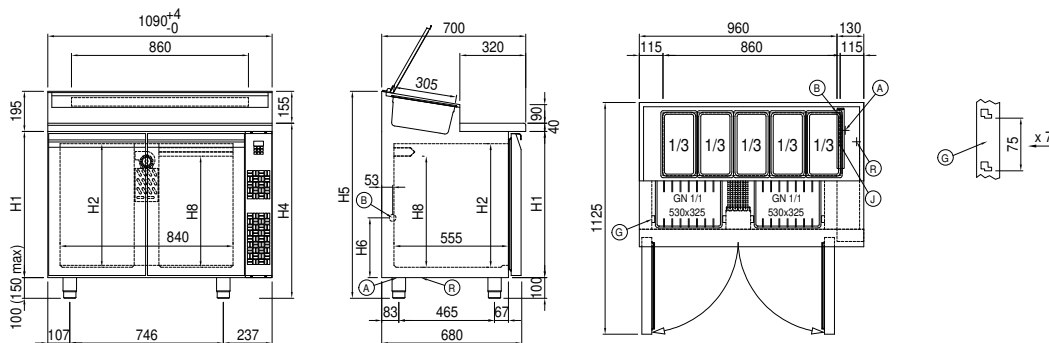

A:	Power supply cable outlet	B:	Condensation water drain	G:	Racks pitch
J:	Automatic evaporation of condensing water	R:	Gas output pipes		