

Client \_\_\_\_\_ Quantity \_\_\_\_\_  
 Project \_\_\_\_\_ Position \_\_\_\_\_

## Master GN counter 2 doors

**Model:** TA13/1MR-660

**Cod:** T10212000203

Master refrigerated counter 2 doors, counter body height 660 mm, top with splashback. Remote refrigeration unit, 5 heavy duty climatic class and R452a refrigerant gas. Temperature range -2°+8°C with ventilated refrigeration. Equipment: 1 GN1/1 plastic coated shelf. Each compartment can be configured with 1/2+1/2, 1/3+2/3, 1/3+1/3+1/3 drawers. Anti-corrosion treated evaporator and electric defrosting. 60 mm insulation thickness - HFO with high insulation performance and low environmental impact (CFC, HCFC, HFC free). AISI 304 stainless steel handle and magnetic triple chamber door gasket, easily replaceable. Reversible, self-closing door opening with 105° stop. AISI 304 stainless steel interior/exterior including external back. Rounded inner corners for easy cleaning. The reinforced modular base in colaminated steel allows installation on wheels, feet, mobile or masonry plinths. Replaceable refrigerant system FSS - Fast Service System - for quick and easy service. Prepared for connection to Cosmo - wi-fi remote supervision system - and ModBus/RTU Rs485 connection.



### Technical data

<b>Top:</b>	With top and splashback
<b>Gross capacity:</b>	256 lt
<b>Temperature range:</b>	-2°+8°C
<b>Refrigerant unit:</b>	remote
<b>Cooling gas:</b>	R452a
<b>Defrost:</b>	Electric
<b>Body height:</b>	660 mm
<b>Valve:</b>	Supplied standard with solenoid
<b>Dimensions:</b>	1090×700×900 mm
<b>Packing dimensions:</b>	1395×800×998 mm
<b>Gross weight:</b>	104 Kg
<b>Voltage:</b>	220-240 V - 50-60 Hz
<b>Total rate:</b>	810 W
<b>Absorbed Current:</b>	3,7 A
<b>Cooling capacity:</b>	519 W*

### Features

<b>Standard equipment:</b>	2 slides, 2 plastic coated GN1/1 shelves
<b>Control:</b>	Electronic, display flush with the panel
<b>Doors:</b>	2 doors, self-closing, reversible with 105° stop
<b>Door gasket:</b>	Magnetic, triple chamber and easily replaceable
<b>Insulation:</b>	60 mm thickness - CFC/HCFC free
<b>Exterior/interior finishing:</b>	Exterior interior and back in AISI 304 stainless steel. Base in colaminated steel.
<b>Inner corners:</b>	Rounded for easy cleaning and ensuring maximum hygiene
<b>Handle:</b>	Stainless steel AISI 304, 2 mm thick
<b>Racks and slides:</b>	Stainless steel AISI 304
<b>Feets:</b>	AISI 304 stainless steel adjustable h 100/150 mm
<b>Cosmo:</b>	Predisposed for Cosmo Hub connection

## Accessories and variants

Drawers 1/2	Internal hygiene H3
Drawers 1/3	Granite flat worktop
Drawers 1/3 + 2/3	Granite worktop with splashback
Special counter body heights 650 mm	Remote condensing unit EMT6165GK
Special counter body heights 700 mm	Adjustable feet h 145/195 mm
Special counter body heights 750 mm	4 Swivel and brake castors h 128 mm
Technical compartment on the left	Brackets for GN pans for drawer
Common technical compartment	GN1/2 container + lids kit for drawer, h 150 mm
Counters without a technical compartment	GN1/3 container + lids kit for drawer, h 150 mm
Lock with key for drawer 1/2	Bottles shelf, stainless steel coating for shelf 350
Lock with key for drawer 1/3	Stainless steel shelf GN1/1
Lock with key for drawer 1/3 + 2/3	Plastic coated shelf GN1/1
LED lighting	Pair of type C slides 505 mm
RAL customisable colouring	Serial interface, RS485 cable
Stainless steel evaporator	Cosmo cable connection kit
Predisposition for connection to CO2 remote control unit	Cosmo wifi connection kit
Alimentazione frequenza 60Hz	Removable plinth GN 2DR h 100 mm
Other special voltage	Removable plinth GN 2DR h 150 mm

## Remote unit technical data

<b>Voltage:</b>	220-240V - 50 Hz
<b>Cooling gas:</b>	R452A
<b>Gross weight:</b>	17 Kg
<b>Dimensions:</b>	450x300x270 mm
<b>Packing dimensions:</b>	470x330x300 mm
<b>Cooling capacity:</b>	Evap. -10°C Cond. +55°C

### COSMO - wi-fi control

Cosmo is The Nice Kitchen's exclusive wi-fi technology that allows Coldline, Modular and Nevo appliances to be connected and monitored from a smartphone. The counter, connected with Cosmo kit via cable to a Cosmo hub (MODI, VISION, THAW.PRO, Levtronic, QUBI) or with Cosmo wi-fi kit, can be monitored by the CosmoApp and receive alerts in case of abnormal operation.

## Technical draw

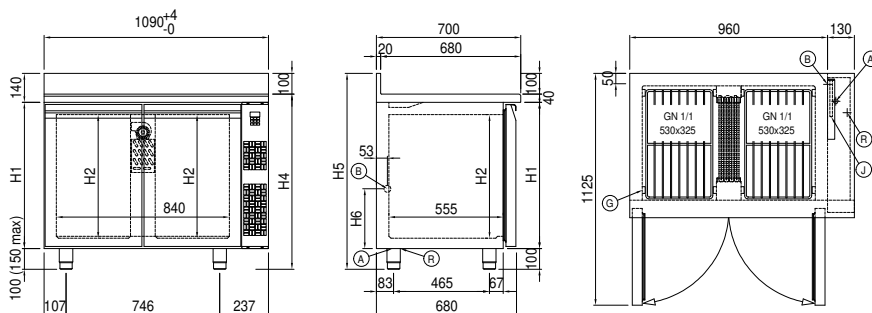

- |   |                                    |                       |
|---|------------------------------------|-----------------------|
| <b>A:</b> Power supply cable outlet                 | <b>B:</b> Condensation water drain | <b>G:</b> Racks pitch |
| <b>J:</b> Automatic evaporation of condensing water | <b>R:</b> Gas output pipes         |                       |