

Client _____ Quantity _____
 Project _____ Position _____

Tavolo Snack GN 4 porte BT

Model: TP21/1B-490

Cod: T10401000404

Snack refrigerated counter 4 doors, counter body height 490 mm, with top. Plug-in refrigeration unit, E energetic class, 5 heavy duty climatic class and R290 ecological refrigerant gas. Temperature range -15°-22°C with ventilated refrigeration. Equipment: 1 GN1/1 plastic coated shelf. Each compartment can be configured with 1/1, 1/2+1/2 drawers. Anti-corrosion treated evaporator and hot gas defrosting. 60 mm insulation thickness - HFO with high insulation performance and low environmental impact (CFC, HCFC, HFC free). AISI 304 stainless steel handle and magnetic triple chamber door gasket, easily replaceable. Reversible, self-closing door opening with 105° stop. AISI 304 stainless steel interior/exterior including external back. Rounded inner corners for easy cleaning. The reinforced modular base in colaminated steel allows installation on wheels, feet, mobile or masonry plinths. Replaceable refrigerant system FSS - Fast Service System - for quick and easy service. Prepared for connection to Cosmo - wi-fi remote supervision system - and ModBus/RTU Rs485 connection.



Technical data

Top:	With top
Gross capacity:	380 lt
Temperature range:	-15°-22°C
Refrigerant unit:	Plug-in
Energetic class:	E
Energy efficiency index:	75,5
Annual consumption:	2725 kW/h annum
24h consumption:	7,466 kW/h/24h
Climate class:	5
Cooling gas:	R290
Defrost:	Hot gas
Body height:	490 mm
Valve:	Supplied standard with solenoid
Dimensions:	2260×700×630 mm
Packing dimensions:	2355×800×998 mm
Gross weight:	200 Kg
Voltage:	220-240 V - 50 Hz
Total rate:	850 W
Absorbed Current:	3,9 A
Cooling capacity:	569 W*
*:	Evap. -30°C Cond. +55°C

Features

Standard equipment:	4 slides, 4 plastic coated GN1/1 shelves
Control:	Electronic, display flush with the panel
Doors:	4 doors, self-closing, reversible with 105° stop
Door gasket:	Magnetic, triple chamber and easily replaceable
Insulation:	60 mm thickness - CFC/HCFC free
Exterior/interior finishing:	Exterior interior and back in AISI 304 stainless steel. Base in colaminated steel.
Inner corners:	Rounded for easy cleaning and ensuring maximum hygiene
Handle:	Stainless steel AISI 304, 2 mm thick
Racks and slides:	Stainless steel AISI 304
Feets:	AISI 304 stainless steel adjustable h 100/150 mm
Cosmo:	Predisposed for Cosmo Hub connection

Accessories and variants

Drawers 1/1	Brackets for GN pans for drawer
Drawers 1/2	GN1/2 container + lids kit for drawer, h 150 mm
Special size of technical compartment	GN1/3 container + lids kit for drawer, h 150 mm
Technical compartment on the left	Bottles shelf, stainless steel coating for shelf 350
Lock with key for drawer 1/1	Stainless steel shelf GN1/1
Lock with key for drawer 1/2	Plastic coated shelf GN1/1
RAL customisable colouring	Pair of type C slides 505 mm
Plug-in water unit	IP44 schuko socket with cover
Alimentazione frequenza 60Hz	Serial interface, RS485 cable
Other special voltage	Cosmo cable connection kit
Adjustable feet h 145/195 mm	Cosmo wifi connection kit
6 Swivel and brake castors h 128 mm	Removable plinth GN 4D h 100 mm

COSMO - wi-fi control

Cosmo is The Nice Kitchen's exclusive wi-fi technology that allows Coldline, Modular and Nevo appliances to be connected and monitored from a smartphone. The counter, connected with Cosmo kit via cable to a Cosmo hub (MODI, VISION, THAW.PRO, Levtronic, QUBI) or with Cosmo wi-fi kit, can be monitored by the CosmoApp and receive alerts in case of abnormal operation.

Technical draw

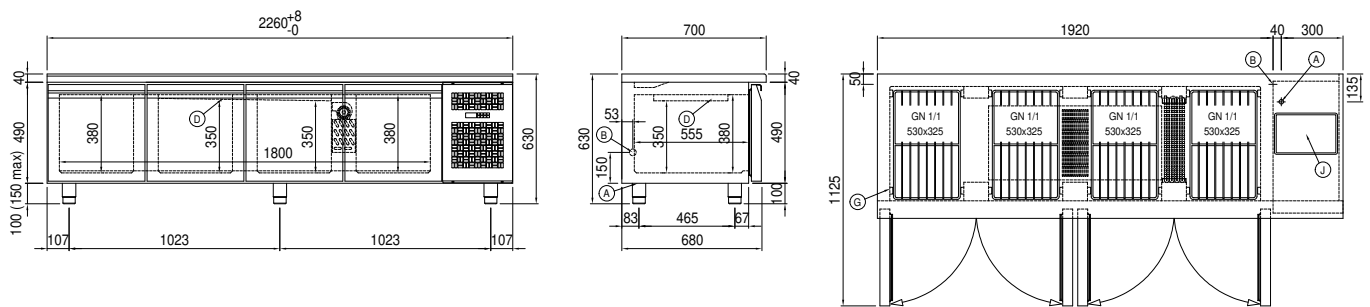

- | | | |
|-------------------------------------|---|----------------------------|
| A: Power supply cable outlet | B: Condensation water drain | D: Airflow conveyor |
| G: Racks pitch | J: Automatic evaporation of condensing water | |