

Client \_\_\_\_\_ Quantity \_\_\_\_\_  
 Project \_\_\_\_\_ Position \_\_\_\_\_

## Master 600 counter 4 doors

**Model:** TP21/1BQ-660

**Cod:** T12401000403

Master 600 refrigerated counter 1 door, counter body height 660 mm, with top. Plug-in refrigeration unit, D energetic class, 5 heavy duty climatic class and R290 ecological refrigerant gas. Temperature range -15°-22°C with ventilated refrigeration. Equipment: 4 325x430 mm plastic coated shelves. Each compartment can be configured with 1/2+1/2, 1/3+2/3, 1/3+1/3+1/3 drawers. Anti-corrosion treated evaporator and hot gas defrosting. 60 mm insulation thickness - HFO with high insulation performance and low environmental impact (CFC, HCFC, HFC free). AISI 304 stainless steel handle and magnetic triple chamber door gasket, easily replaceable. Reversible, self-closing door opening with 105° stop. AISI 304 stainless steel interior/exterior including external back. Rounded inner corners for easy cleaning. The reinforced modular base in colaminated steel allows installation on wheels, feet, mobile or masonry plinths. Replaceable refrigerant system FSS - Fast Service System - for quick and easy service. Prepared for connection to Cosmo - wi-fi remote supervision system - and ModBus/RTU Rs485 connection.



### Technical data

<b>Top:</b>	With top
<b>Gross capacity:</b>	450 lt
<b>Temperature range:</b>	-15°-22°C
<b>Refrigerant unit:</b>	Plug-in
<b>Energetic class:</b>	D
<b>Energy efficiency index:</b>	75,3
<b>Annual consumption:</b>	2970 kW/h annum
<b>24h consumption:</b>	8,137 kW/h/24h
<b>Climate class:</b>	5
<b>Cooling gas:</b>	R290
<b>Defrost:</b>	Hot gas
<b>Body height:</b>	660 mm
<b>Valve:</b>	Supplied standard with solenoid
<b>Dimensions:</b>	2260×600×800 mm
<b>Packing dimensions:</b>	2355×800×998 mm
<b>Gross weight:</b>	198 Kg
<b>Voltage:</b>	220-240 V - 50 Hz
<b>Total rate:</b>	850 W
<b>Absorbed Current:</b>	3,9 A
<b>Cooling capacity:</b>	569 W*
<b>*:</b>	Evap. -30°C Cond. +55°C

### Features

<b>Standard equipment:</b>	4 slides, 4 plastic coated 325x430 mm shelves
<b>Control:</b>	Electronic, display flush with the panel
<b>Doors:</b>	4 doors, self-closing, reversible with 105° stop
<b>Door gasket:</b>	Magnetic, triple chamber and easily replaceable
<b>Insulation:</b>	60 mm thickness - CFC/HCFC free
<b>Exterior/interior finishing:</b>	Exterior interior and back in AISI 304 stainless steel. Base in colaminated steel.
<b>Inner corners:</b>	Rounded for easy cleaning and ensuring maximum hygiene
<b>Handle:</b>	Stainless steel AISI 304, 2 mm thick
<b>Racks and slides:</b>	Stainless steel AISI 304
<b>Feets:</b>	AISI 304 stainless steel adjustable h 100/150 mm
<b>Cosmo:</b>	Predisposed for Cosmo Hub connection

## Accessories and variants

Drawers 1/2	Granite flat worktop
Drawers 1/3	Granite worktop with splashback
Drawers 1/3 + 2/3	Service water sink Ø 300 mm
Special counter body heights 650 mm	Single lever mixer hole Ø 3/4
Special counter body heights 700 mm	Adjustable feet h 145/195 mm
Special counter body heights 750 mm	6 Swivel and brake castors h 128 mm
Technical compartment on the left	Brackets for GN pans for drawer
Lock with key for drawer 1/2	GN1/2 container + lids kit for drawer, h 150 mm
Lock with key for drawer 1/3	GN1/3 container + lids kit for drawer, h 150 mm
Lock with key for drawer 1/3 + 2/3	Plastic coated shelf 325x430
LED lighting	Pair of type C slides 405 mm
RAL customisable colouring	Serial interface, RS485 cable
Plug-in water unit	IP44 schuko socket with cover
Alimentazione frequenza 60Hz	Cosmo cable connection kit
Other special voltage	Cosmo wifi connection kit
Internal hygiene H3	Removable plinth CQ 4D h 100 mm

## COSMO - wi-fi control

Cosmo is The Nice Kitchen's exclusive wi-fi technology that allows Coldline, Modular and Nevo appliances to be connected and monitored from a smartphone. The counter, connected with Cosmo kit via cable to a Cosmo hub (MODI, VISION, THAW.PRO, Levtronic, QUBI) or with Cosmo wi-fi kit, can be monitored by the CosmoApp and receive alerts in case of abnormal operation.

## Technical draw

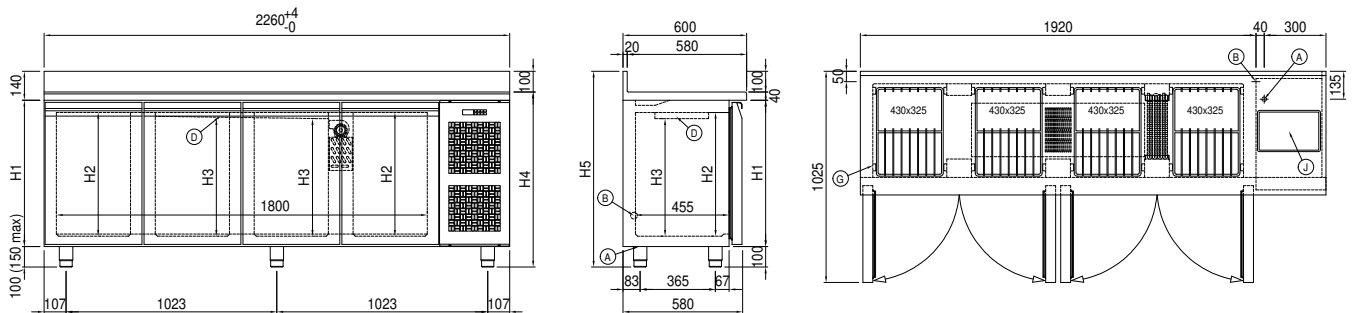

- |                                     |   |                            |
|-------------------------------------|---|----------------------------|
| <b>A:</b> Power supply cable outlet | <b>B:</b> Condensation water drain                  | <b>D:</b> Airflow conveyor |
| <b>G:</b> Racks pitch               | <b>J:</b> Automatic evaporation of condensing water |                            |