

Client _____ Quantity _____
 Project _____ Position _____

Master 600 counter 4 doors

Model: TA21/1MQR-660

Cod: T12412000203

Master 600 refrigerated counter 1 door, counter body height 660 mm, top with splashback. Remote refrigeration unit, 5 heavy duty climatic class and R452a refrigerant gas. Temperature range -2°+8°C with ventilated refrigeration. Equipment: 4 325x430 mm plastic coated shelves. Each compartment can be configured with 1/2+1/2, 1/3+2/3, 1/3+1/3+1/3 drawers. Anti-corrosion treated evaporator and electric defrosting. 60 mm insulation thickness - HFO with high insulation performance and low environmental impact (CFC, HCFC, HFC free). AISI 304 stainless steel handle and magnetic triple chamber door gasket, easily replaceable. Reversible, self-closing door opening with 105° stop. AISI 304 stainless steel interior/exterior including external back. Rounded inner corners for easy cleaning. The reinforced modular base in colaminated steel allows installation on wheels, feet, mobile or masonry plinths. Replaceable refrigerant system FSS - Fast Service System - for quick and easy service. Prepared for connection to Cosmo - wi-fi remote supervision system - and ModBus/RTU Rs485 connection.



Technical data

| | |
|---------------------|---------------------------------|
| Top: | With top and splashback |
| Gross capacity: | 450 lt |
| Temperature range: | -2°+8°C |
| Refrigerant unit: | remote |
| Cooling gas: | R452a (GWP=2.141) |
| Defrost: | Electric |
| Body height: | 660 mm |
| Valve: | Supplied standard with solenoid |
| Dimensions: | 2050×600×900 mm |
| Packing dimensions: | 2355×800×998 mm |
| Net / gross weight: | 153 Kg / 163 Kg |
| Net / gross volume: | 268 lt / 450 lt |
| Voltage: | 220-240 V - 50-60 Hz |
| Total rate: | 810W - 3,7A |
| Cooling capacity: | 668 W* |
| *: | Evap. -10°C Cond. +55°C |

Features

| | |
|------------------------------|--|
| Standard equipment: | 4 slides, 4 plastic coated 325x430 mm shelves |
| Control: | Electronic, display flush with the panel |
| Doors: | 4 doors, self-closing, reversible with 105° stop |
| Door gasket: | Magnetic, triple chamber and easily replaceable |
| Insulation: | 60 mm thickness - CFC/HCFC free |
| Exterior/interior finishing: | Exterior interior and back in AISI 304 stainless steel. Base in colaminated steel. |
| Inner corners: | Rounded for easy cleaning and ensuring maximum hygiene |
| Handle: | Stainless steel AISI 304, 2 mm thick |
| Racks and slides: | Stainless steel AISI 304 |
| Feets: | AISI 304 stainless steel adjustable h 100/150 mm |
| Cosmo: | Predisposed for Cosmo Hub connection |

Accessories and variants

| | |
|--|---|
| Drawers 1/2 | Internal hygiene H3 |
| Drawers 1/3 | Granite flat worktop |
| Drawers 1/3 + 2/3 | Granite worktop with splashback |
| Special counter body heights 650 mm | Remote condensing unit NEK6210GK |
| Special counter body heights 700 mm | Adjustable feet h 145/195 mm |
| Special counter body heights 750 mm | 6 Swivel and brake castors h 128 mm |
| Technical compartment on the left | Brackets for GN pans for drawer |
| Common technical compartment | GN1/2 container + lids kit for drawer, h 150 mm |
| Counters without a technical compartment | GN1/3 container + lids kit for drawer, h 150 mm |
| Lock with key for drawer 1/2 | Plastic coated shelf 325x430 |
| Lock with key for drawer 1/3 | Pair of type C slides 405 mm |
| Lock with key for drawer 1/3 + 2/3 | Serial interface, RS485 cable |
| LED lighting | Cosmo cable connection kit |
| RAL customisable colouring | Cosmo wifi connection kit |
| Predisposition for connection to CO2 remote control unit | Removable plinth CQ 4DR h 100 mm |
| Alimentazione frequenza 60Hz | Removable plinth CQ 4DR h 150 mm |
| Other special voltage | R134a valve |

Remote unit technical data

| | |
|----------------------------|-------------------------|
| Voltage: | 220-240 V - 50 Hz |
| Assorbimento Unità Remota: | 500W - 2,3A |
| Cooling gas: | R452A |
| Gross weight: | 16 Kg |
| Dimensions: | 480x330x295 mm |
| Pipe delivery: | Ø 1/4" |
| Pipe suction: | Ø 3/8" |
| Packing dimensions: | 540x345x310 mm |
| Cooling capacity: | Evap. -10°C Cond. +55°C |

COSMO - wi-fi control

Cosmo is The Nice Kitchen's exclusive wi-fi technology that allows Coldline, Modular and Nevo appliances to be connected and monitored from a smartphone. The counter, connected with Cosmo kit via cable to a Cosmo hub (MODI, VISION, THAW.PRO, Levtronic, QUBI) or with Cosmo wi-fi kit, can be monitored by the CosmoApp and receive alerts in case of abnormal operation.

Technical draw

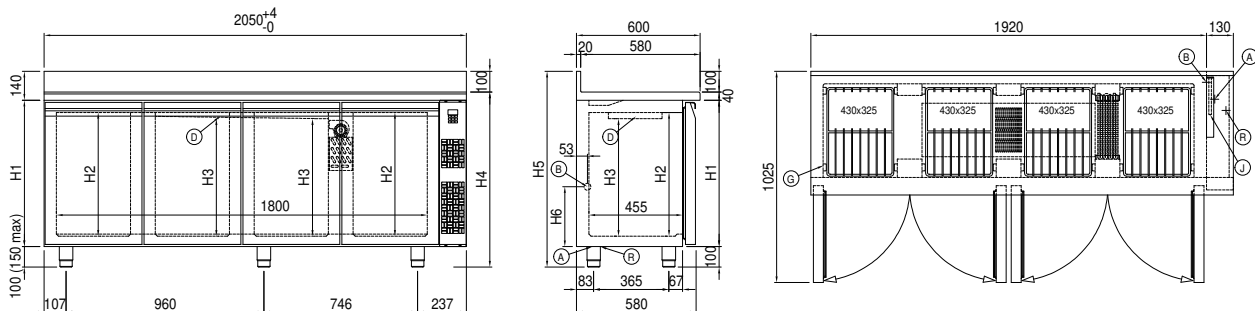

- | | | |
|------------------------------|--|---------------------|
| A: Power supply cable outlet | B: Condensation water drain | D: Airflow conveyer |
| G: Racks pitch | J: Automatic evaporation of condensing water | R: Gas output pipes |

In order to constantly offer the best possible products we reserve the right to make changes on technical specifications without incurring any obligation for equipment previously or subsequently sold.