

Client _____ Quantity _____

Project _____ Position _____

Pastry EN60x40 counter 1 door

Model: TS09/1MJ-660

Cod: T20100000203



Technical data

Top:	Without top
Temperature range:	-2°+8°C
Refrigerant unit:	Plug-in
Energetic class:	B
Energy efficiency index:	27,7
Annual consumption:	578 kW/h annum
24h consumption:	1,584 kW/h/24h
Climate class:	5
Cooling gas:	R290
Refrigerant Charge:	110g
Defrost:	Hot gas
Body height:	660 mm
Valve:	Supplied standard with solenoid
Dimensions:	895×780×760 mm
Packing dimensions:	990×900×998 mm
Voltage:	220-240 V - 50 Hz
Cooling capacity:	406 W*
*:	Evap. -10°C Cond. +55°C

Features

Standard equipment:	4 slides EN60x40
Control:	Electronic, display flush with the panel
Doors:	1 door, self-closing, reversible with 105° stop
Door gasket:	Magnetic, triple chamber and easily replaceable
Insulation:	60 mm thickness - CFC/HCFC free
Exterior/interior finishing:	Exterior interior and back in AISI 304 stainless steel. Base in colaminated steel.
Inner corners:	Rounded for easy cleaning and ensuring maximum hygiene
Handle:	Stainless steel AISI 304, 2 mm thick
Racks and slides:	Stainless steel AISI 304
Feets:	AISI 304 stainless steel adjustable h 100/150 mm
Cosmo:	Predisposed for Cosmo Hub connection

Accessories and variants

Drawers 1/2	Granite flat worktop
Drawers 1/3	Granite worktop with splashback
Drawers 1/3 + 2/3	Adjustable feet h 145/195 mm
Technical compartment on the left	4 Swivel and brake castors h 128 mm
Lock with key for drawer 1/2	Aluminium coated backingan EN60x40 h 20 mm
Lock with key for drawer 1/3	Stainless steel shelf EN60x40
Lock with key for drawer 1/3 + 2/3	Plastic coated shelf EN60x40
RAL customisable colouring	Pair of type L slides 605 mm
Plug-in water unit	IP44 schuko socket with cover
Stainless steel evaporator	Serial interface, RS485 cable
Alimentazione frequenza 60Hz	Cosmo cable connection kit
Other special voltage	Removable plinth EN 1D h 50 mm
Internal hygiene H3	Removable plinth EN 1D h 100 mm

COSMO - wi-fi control

Cosmo è la tecnologia wi-fi che permette di connettere e monitorare da smartphone gli apparecchi Coldline. Collega i tavoli Pastry ad un Cosmo hub (MODI, VISION o LEVTRONIC) e dall'app potrai controllare le condizioni di funzionamento di ogni macchina e ricevere alert in caso di funzionamento anomalo.

Technical draw

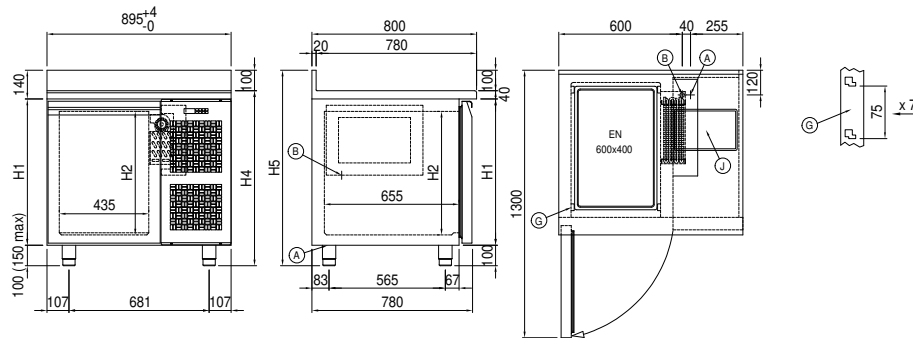

A: Power supply cable outlet

B: Condensation water drain

G: Racks pitch

J: Automatic evaporation of condensing water