

Client _____ Quantity _____

Project _____ Position _____

Pastry EN60x40 counter 1 door

Model: TS09/1MJR-660

Cod: T20110000203



Technical data

Top:	Without top
Temperature range:	-2°+8°C
Refrigerant unit:	remote
Cooling gas:	R452a
Defrost:	Electric
Body height:	660 mm
Valve:	Supplied standard with solenoid
Dimensions:	755×780×760 mm
Packing dimensions:	990×900×998 mm
Voltage:	220-240 V - 50-60 Hz
Cooling capacity:	368 W*
*:	Evap. -10°C Cond. +55°C

Features

Standard equipment:	4 slides EN60x40
Control:	Electronic, display flush with the panel
Doors:	1 door, self-closing, reversible with 105° stop
Door gasket:	Magnetic, triple chamber and easily replaceable
Insulation:	60 mm thickness - CFC/HCFC free
Exterior/interior finishing:	Exterior interior and back in AISI 304 stainless steel. Base in colaminated steel.
Inner corners:	Rounded for easy cleaning and ensuring maximum hygiene
Handle:	Stainless steel AISI 304, 2 mm thick
Racks and slides:	Stainless steel AISI 304
Feets:	AISI 304 stainless steel adjustable h 100/150 mm
Cosmo:	Predisposed for Cosmo Hub connection

Accessories and variants

Drawers 1/3	Granite worktop with splashback
Drawers 1/3 + 2/3	Granite worktop with splashback
Technical compartment on the left	Remote condensing unit EMT6144GK
Common technical compartment	Adjustable feet h 145/195 mm
Counters without a technical compartment	4 Swivel and brake castors h 128 mm
Lock with key for drawer 1/2	Aluminium coated backingan EN60x40 h 20 mm
Lock with key for drawer 1/3	Stainless steel shelf EN60x40
Lock with key for drawer 1/3 + 2/3	Plastic coated shelf EN60x40
RAL customisable colouring	Pair of type L slides 605 mm
Stainless steel evaporator	R134a valve
Predisposition for connection to CO2 remote control unit	Serial interface, RS485 cable
Alimentazione frequenza 60Hz	Cosmo cable connection kit
Other special voltage	Removable plinth EN 1DR h 50 mm
Internal hygiene H3	Removable plinth EN 1DR h 100 mm
Granite flat worktop	Removable plinth EN 1DR h 150 mm

Remote unit technical data

Voltage:	220-240 V - 50 Hz
Cooling gas:	R404-R452
Gross weight:	17 Kg
Dimensions:	450×300×270 mm
Pipe delivery:	Ø 1/4"
Pipe suction:	Ø 3/8"
Packing dimensions:	470×330×300 mm
Cooling capacity:	Evap. -10°C Cond. +55°C

COSMO - wi-fi control

Cosmo è la tecnologia wi-fi che permette di connettere e monitorare da smartphone gli apparecchi Coldline. Collega i tavoli Pastry ad un Cosmo hub (MODI, VISION o LEVTRONIC) e dall'app potrai controllare le condizioni di funzionamento di ogni macchina e ricevere alert in caso di funzionamento anomalo.

Technical draw

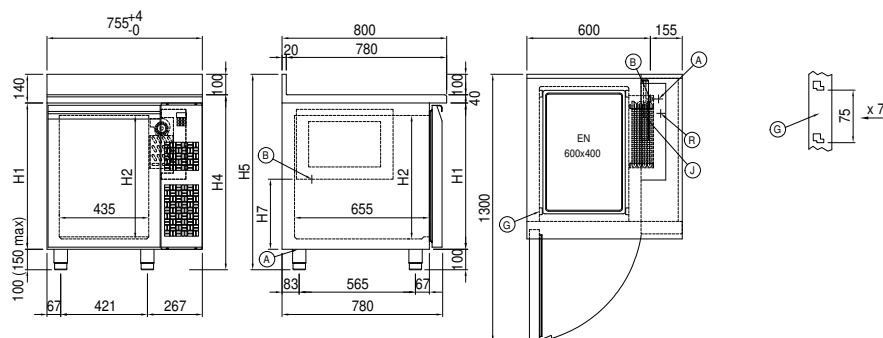

A: Power supply cable outlet

B: Condensation water drain

G: Racks pitch

J: Automatic evaporation of condensing water

R: Gas output pipes