

Client _____ Quantity _____

Project _____ Position _____

Pastry EN60x40 counter 4 doors

Model: TS21/1MJ-760

Cod: T20400000202



Technical data

Top:	Without top
Temperature range:	-2°+8°C
Refrigerant unit:	Plug-in
Energetic class:	C
Energy efficiency index:	39,7
Annual consumption:	1274 kW/h annum
24h consumption:	3,49 kW/h/24h
Climate class:	5
Cooling gas:	R290
Refrigerant Charge:	110g
Defrost:	Hot gas
Body height:	760 mm
Valve:	Supplied standard with solenoid
Dimensions:	2560×780×860 mm
Packing dimensions:	2655×900×998 mm
Voltage:	220-240 V - 50 Hz
Cooling capacity:	406 W*
*:	Evap. -10°C Cond. +55°C

Features

Standard equipment:	16 slides EN60x40
Control:	Electronic, display flush with the panel
Doors:	4 doors, self-closing, reversible with 105° stop
Door gasket:	Magnetic, triple chamber and easily replaceable
Insulation:	60 mm thickness - CFC/HCFC free
Exterior/interior finishing:	Exterior interior and back in AISI 304 stainless steel. Base in colaminated steel.
Inner corners:	Rounded for easy cleaning and ensuring maximum hygiene
Handle:	Stainless steel AISI 304, 2 mm thick
Racks and slides:	Stainless steel AISI 304
Feets:	AISI 304 stainless steel adjustable h 100/150 mm
Cosmo:	Predisposed for Cosmo Hub connection

In order to constantly offer the best possible products we reserve the right to make changes on technical specifications without incurring any obligation for equipment previously or subsequently sold.

Accessories and variants

Drawers 1/2	Granite worktop with splashback
Drawers 1/3	Service water sink Ø 300 mm
Drawers 1/3 + 2/3	Single lever mixer hole Ø 3/4
Technical compartment on the left	Adjustable feet h 145/195 mm
Lock with key for drawer 1/2	6 Swivel and brake castors h 128 mm
Lock with key for drawer 1/3	Aluminium coated backingan EN60x40 h 20 mm
Lock with key for drawer 1/3 + 2/3	Stainless steel shelf EN60x40
RAL customisable colouring	Plastic coated shelf EN60x40
Plug-in water unit	Pair of type L slides 605 mm
Stainless steel evaporator	IP44 schuko socket with cover
Alimentazione frequenza 60Hz	Serial interface, RS485 cable
Other special voltage	Cosmo cable connection kit
Internal hygiene H3	Removable plinth EN 4D h 50 mm
Granite flat worktop	Removable plinth EN 4D h 100 mm

COSMO - wi-fi control

Cosmo è la tecnologia wi-fi che permette di connettere e monitorare da smartphone gli apparecchi Coldline. Collega i tavoli Pastry ad un Cosmo hub (MODI, VISION o LEVTRONIC) e dall'app potrai controllare le condizioni di funzionamento di ogni macchina e ricevere alert in caso di funzionamento anomalo.

Technical draw

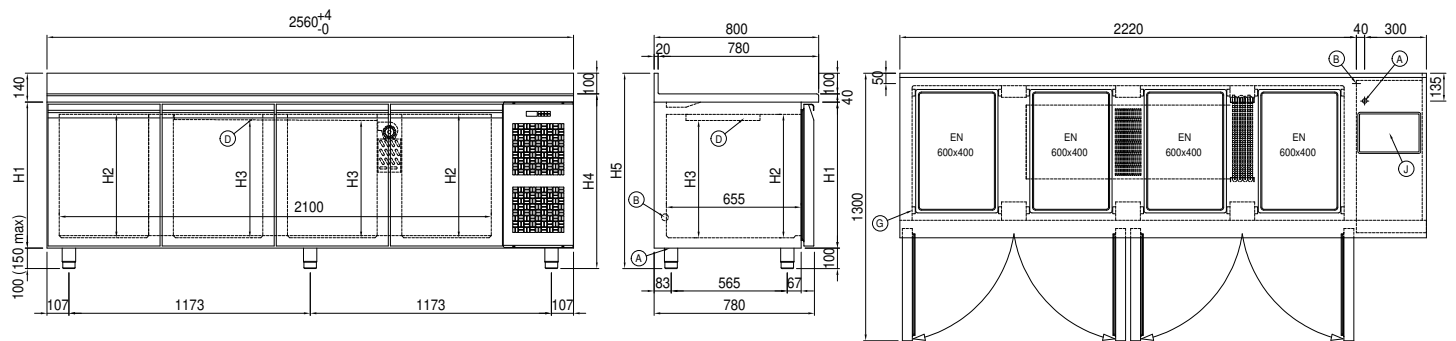

- | | | |
|------------------------------|--|---------------------|
| A: Power supply cable outlet | B: Condensation water drain | D: Airflow conveyor |
| G: Racks pitch | J: Automatic evaporation of condensing water | |

In order to constantly offer the best possible products we reserve the right to make changes on technical specifications without incurring any obligation for equipment previously or subsequently sold.