

Client _____ Quantity _____
 Project _____ Position _____

Pizza Base EN60x40 counter 1 door

Model: TZO9/1MR-710

Cod: T40110000201

Pizza refrigerated base 1 door, counter body height 710 mm, without top. Remote refrigeration unit, 5 heavy duty climatic class and R452a refrigerant gas. Temperature range -2°+8°C with ventilated refrigeration. Equipment: 4 pairs of slides for EN60x40 trays. Each compartment can be configured with refrigerated and neutral drawers. Anti-corrosion treated evaporator and electric defrosting. 60 mm insulation thickness - HFO with high insulation performance and low environmental impact (CFC, HCFC, HFC free). AISI 304 stainless steel handle and magnetic triple chamber door gasket, easily replaceable. Reversible, self-closing door opening with 105° stop. AISI 304 stainless steel interior/exterior including external back. Rounded inner corners for easy cleaning. The reinforced modular base in colaminated steel allows installation on wheels, feet, mobile or masonry plinths. Replaceable refrigerant system FSS - Fast Service System - for quick and easy service. Prepared for connection to Cosmo - wi-fi remote supervision system - and ModBus/RTU Rs485 connection.



Technical data

Top:	Without top
Gross capacity:	171 lt
Temperature range:	-2°+8°C
Refrigerant unit:	remote
Cooling gas:	R452a
Defrost:	Electric
Body height:	710 mm
Valve:	Supplied standard with solenoid
Dimensions:	685×780×810 mm
Packing dimensions:	990×900×998 mm
Gross weight:	75 Kg
Voltage:	220-240 V - 50-60 Hz
Total rate:	710 W
Absorbed Current:	3,2 A
Cooling capacity:	368 W*

Features

Standard equipment:	4 slides EN60x40
Control:	Electronic, display flush with the panel
Doors:	1 door, self-closing, reversible with 105° stop
Door gasket:	Magnetic, triple chamber and easily replaceable
Insulation:	60 mm thickness - CFC/HCFC free
Exterior/interior finishing:	Exterior and interior AISI 304 stainless steel.
Inner corners:	Rounded for easy cleaning and ensuring maximum hygiene
Handle:	Stainless steel AISI 304, 2 mm thick
Racks and slides:	Stainless steel AISI 304
Feets:	AISI 304 stainless steel adjustable h 100/150 mm
Cosmo:	Predisposed for Cosmo Hub connection

Accessories and variants

Drawers 1/2	1+1 Neutral drawers h 710 mm
Drawers 1/3	Adjustable feet h 145/195 mm
Drawers 1/3 + 2/3	4 Swivel and brake castors h 128 mm
Lock with key for drawer 1/2	Frame fitted with telescopic EN60x40 slides
Lock with key for drawer 1/3	EN60x40 Pizza container h 60 mm
Lock with key for drawer 1/3 + 2/3	Aluminium coated backingan EN60x40 h 20 mm
Predisposition for connection to CO2 remote control unit	Pair of type L slides 605 mm
Alimentazione frequenza 60Hz	Serial interface, RS485 cable
Other special voltage	Cosmo cable connection kit
Remote condensing unit EMT6144GK	Cosmo wifi connection kit
7 Neutral drawers h 710 mm	Removable plinth EN 1DR h 100 mm
3+1 Neutral drawers h 710 mm	Removable plinth EN 1DR h 150 mm

Remote unit technical data

Voltage:	220-240 V - 50 Hz
Cooling gas:	R404-R452
Gross weight:	17 Kg
Dimensions:	450x300x270
Packing dimensions:	470x330x300
Cooling capacity:	Evap. -10°C Cond. +55°C

COSMO - wi-fi control

Cosmo is The Nice Kitchen's exclusive wi-fi technology that allows Coldline, Modular and Nevo appliances to be connected and monitored from a smartphone. The counter, connected with Cosmo kit via cable to a Cosmo hub (MODI, VISION, THAW.PRO, Levtronic, QUBI) or with Cosmo wi-fi kit, can be monitored by the CosmoApp and receive alerts in case of abnormal operation.

Technical draw

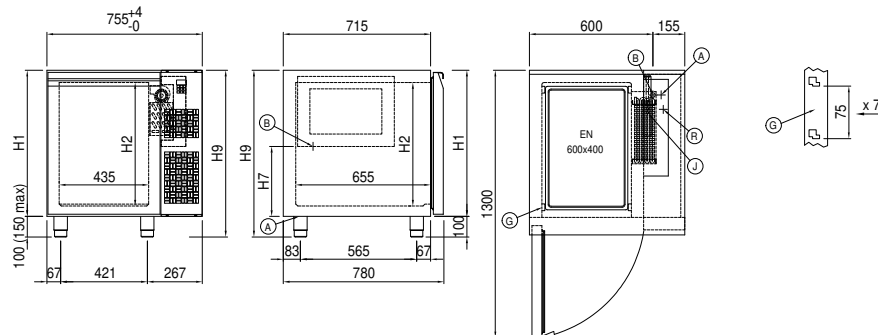

A:	Power supply cable outlet	B:	Condensation water drain	G:	Racks pitch
J:	Automatic evaporation of condensing water	R:	Gas output pipes		