

Client \_\_\_\_\_ Quantity \_\_\_\_\_  
 Project \_\_\_\_\_ Position \_\_\_\_\_

## Modi Active Blast Chiller

**Model:** W6AGSR

**Cod:** W11068011001

Modi multifunction blast chiller 6 trays Active version, depth 700 mm, temperature range -40°+65°C. It is equipped with the functions: blast chilling, blast freezing, manual cycle, thawing, proving, holding, desiccation, chocolate. Remote cooling system with R452a refrigerant gas. 4,3" touch screen on the door and operating mode with customisable recipes, by time or with core probe. Adjustable ventilation 25-100%. Blast chilling yield +90/+3°C - 21 Kg; blast freezing yield +90/-18°C - 15 Kg. 5 heavy duty climatic class, forced air defrost. 60 mm insulation thickness - HFO with high insulation performance and low environmental impact (CFC, HCFC, HFC free). Electronic expansion valve and anti-corrosion painted evaporator. Cushioned door with anti-odour system with Easily replaceable triple chamber magnetic gasket, core probe with screw connector and housing on the port. Exterior and interior AISI 304 stainless steel, fan unit and condenser cover removable without tools. Equipment: 6 GN1/1-EN60x40 pairs of slides. ModBus/RTU Rs485 connection as standard. Cosmo: wi-fi connection for remote monitoring via Cosmo App. When wired to Coldline counters and cabinets acts as a hub for remote monitoring of connected equipment.



### Technical data

<b>Top:</b>	Thickness 4 cm. Reinforced in order to place an oven
<b>Gross capacity:</b>	136 lt
<b>Temperature range:</b>	-40°+65°C
<b>Ventilation range:</b>	25% - 100%
<b>Humidifier:</b>	Not available
<b>Refrigerant unit:</b>	remote
<b>Yield +90/+3:</b>	21 Kg
<b>Yield +90/-18:</b>	15 Kg
<b>Cooling gas:</b>	R452a
<b>Defrost:</b>	Forced air
<b>Valve:</b>	Electronic expansion valve
<b>Dimensions:</b>	780×700×913 mm
<b>Packing dimensions:</b>	875×915×1141 mm
<b>Gross weight:</b>	90 Kg
<b>Voltage:</b>	220-240 V - 50-60 Hz

### Features

<b>Functions:</b>	Blast chilling, shock freezing, thawing, proving, holding, desiccation, chocolate, manual cycle
<b>Standard equipment:</b>	6 slides GN1/1, EN60x40
<b>Control:</b>	4,3" touch screen display with USB port
<b>Doors:</b>	Cushioned, with anti-odor system
<b>Door gasket:</b>	Magnetic, triple chamber and easily replaceable
<b>Core probe:</b>	Needle probe with 1 reading point, quick-release and easily replaceable
<b>Insulation:</b>	60 mm thickness - CFC/HCFC free
<b>Exterior/interior finishing:</b>	Exterior and interior AISI 304 stainless steel.
<b>Inner corners:</b>	Rounded for easy cleaning and ensuring maximum hygiene
<b>Handle:</b>	Stainless steel AISI 304, 2 mm thick
<b>Racks and slides:</b>	Stainless steel AISI 304, quick release
<b>Feets:</b>	AISI 304 stainless steel adjustable h 100/150 mm
<b>Cosmo:</b>	Wi-Fi remote control system

## Accessories and variants

RAL customisable colouring	Lowered foot h 55/70 mm
Sonda al cuore a 3 punti di lettura	4 Swivel and brake castors h 128 mm
Sonda al cuore riscaldata a 1 punto di lettura	Stainless steel shelf GN1/1
Reverse door opening from standard	Plastic coated shelf GN1/1
Alimentazione frequenza 60Hz	Stainless steel shelf EN60x40
Other special voltage	Plastic coated shelf EN60x40
Remote condensing unit W6-W7T	Pair of type L slides 398 mm GN-EN

## Remote unit technical data

<b>Voltage:</b>	220-240 V - 50 Hz
<b>Cooling gas:</b>	R404-R452a
<b>Gross weight:</b>	52 Kg
<b>Dimensions:</b>	780x752x280 mm
<b>Cooling capacity:</b>	Evap. -10°C Cond. +45°C

## COSMO - wi-fi control

Cosmo is The Nice Kitchen's exclusive wi-fi technology that allows MODI blast chillers to be connected, updated and monitored from smartphones. MODI is also a Cosmo hub and allows remote supervision of the Coldline appliances connected to it. From the CosmoApp you can check the operating conditions of each machine and receive alerts in the event of abnormal operation.

## Technical draw

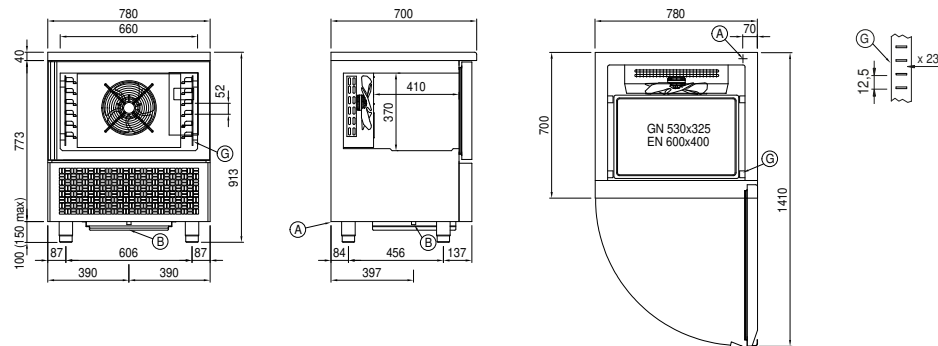

**A:** Power supply cable outlet

**B:** Condensation water drain

**G:** Racks pitch