

Client _____ Quantity _____
 Project _____ Position _____

Modi Up Roll-in Blast Chiller

Model: W20KU

Cod: W12203000001



Modi multifunction blast chiller 20 trays Up version, Roll-in, temperature range -40°+10°C. It is equipped with the functions: blast chilling, blast freezing, manual cycle. Plug-In refrigeration system with air condensation with R452a refrigerant gas. 4.3" touch screen and operating mode with customisable recipes, by time or with core probe. Adjustable ventilation 25-100%. Blast chilling yield +90/+3°C - 88 Kg; blast freezing yield +90/-18°C - 62 Kg. 5 heavy duty climatic class, forced air defrost. 75 mm insulation thickness - HFO with high insulation performance and low environmental impact (CFC, HCFC, HFC free). Electronic expansion valve and anti-corrosion painted evaporator. Cushioned door with anti-odour system with Easily replaceable triple chamber magnetic gasket and core probe with screw connector. Exterior and interior AISI 304 stainless steel, removable fan unit and condenser cover. For GN1/1-EN60x40 trolleys. ModBus/RTU Rs485 connection as standard. Cosmo: wi-fi connection for remote monitoring via Cosmo App. When wired to Coldline counters and cabinets acts as a hub for remote monitoring of connected equipment.

Technical data

Gross capacity:	977 lt
Temperature range:	-40°+10°C
Ventilation range:	25% - 100%
Humidifier:	Not available
Refrigerant unit:	Plug-in
Yield +90/+3:	88 Kg
Yield +90/-18:	62 Kg
Climate class:	5
Cooling gas:	R452a (GWP=2.141)
Refrigerant Charge:	5000g
Defrost:	Forced air
Valve:	Electronic expansion valve
Dimensions:	810×1015×2240 mm
Packing dimensions:	905×1130×2365 mm
Net / gross weight:	230 Kg / 240 Kg
Net / gross volume:	ND / 977 lt
Voltage:	400-415 V - 50-60 Hz
Total rate:	6450 W - 12,45 A
Cooling capacity:	7751 W*
*:	Evap. -10°C Cond. +45°C

Features

Functions:	Blast chilling, shock freezing, continuous cycle
Control:	4,3" touch screen display with USB port
Doors:	Cushioned, with anti-odour system
Door gasket:	Magnetic, triple chamber and easily replaceable
Core probe:	Needle probe with 1 reading point, quick-release and easily replaceable
Insulation:	75 mm thickness - CFC/HCFC free
Exterior/interior finishing:	Exterior and interior AISI 304 stainless steel.
Inner corners:	Rounded for easy cleaning and ensuring maximum hygiene
Handle:	Stainless steel AISI 304, 2 mm thick
Racks and slides:	Stainless steel AISI 304, quick release
Cosmo:	Wi-Fi remote control system

In order to constantly offer the best possible products we reserve the right to make changes on technical specifications without incurring any obligation for equipment previously or subsequently sold.

Accessories and variants

RAL customisable colouring	Alimentazione Trifase 50Hz oppure 60Hz
Sonda al cuore a 3 punti di lettura	Alimentazione frequenza 60Hz
Sonda al cuore riscaldata a 1 punto di lettura	Other special voltage
Reverse door opening from standard	Trolley GN1/1 20 trays 598x530x1630 mm
Alimentazione Monofase 50Hz oppure 60Hz	Sterilizing UV lamp

COSMO - wi-fi control

Cosmo is The Nice Kitchen's exclusive wi-fi technology that allows MODI blast chillers to be connected, updated and monitored from smartphones. MODI is also a Cosmo hub and allows remote supervision of the Coldline appliances connected to it. From the CosmoApp you can check the operating conditions of each machine and receive alerts in the event of abnormal operation.

Technical draw

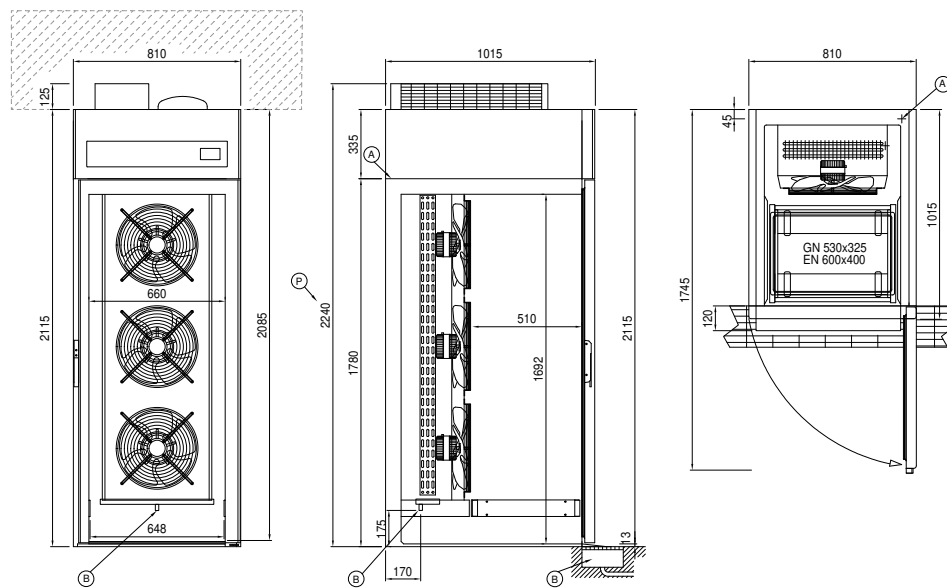

A: Power supply cable outlet

B: Condensation water drain

Q: Plug-In

R: Gas output pipes