

Client \_\_\_\_\_ Quantity \_\_\_\_\_  
 Project \_\_\_\_\_ Position \_\_\_\_\_

## Modi Up Roll-in Blast Chiller

**Model:** W20KUR

**Cod:** W12205000001



Modi multifunction blast chiller 20 trays Up version, Roll-in, temperature range -40°+10°C. It is equipped with the functions: blast chilling, blast freezing, manual cycle. Remote cooling system with R452a refrigerant gas. 4.3" touch screen and operating mode with customisable recipes, by time or with core probe. Adjustable ventilation 25-100%. Blast chilling yield +90/+3°C - 88 Kg; blast freezing yield +90/-18°C - 62 Kg. 5 heavy duty climatic class, forced air defrost. 75 mm insulation thickness - HFO with high insulation performance and low environmental impact (CFC, HCFC, HFC free). Electronic expansion valve and anti-corrosion painted evaporator. Easily replaceable triple chamber magnetic gasket and core probe with screw connector. Exterior and interior AISI 304 stainless steel, removable fan unit and condenser cover. For GN1/1-EN60x40 trolleys. ModBus/RTU Rs485 connection as standard. Cosmo: wi-fi connection for remote monitoring via Cosmo App. When wired to Coldline counters and cabinets acts as a hub for remote monitoring of connected equipment.

### Technical data

<b>Gross capacity:</b>	977 lt
<b>Temperature range:</b>	-40°+10°C
<b>Ventilation range:</b>	25% - 100%
<b>Humidifier:</b>	Not available
<b>Refrigerant unit:</b>	remote
<b>Yield +90/+3:</b>	88 Kg
<b>Yield +90/-18:</b>	62 Kg
<b>Cooling gas:</b>	R452a
<b>Defrost:</b>	Forced air
<b>Valve:</b>	Electronic expansion valve
<b>Dimensions:</b>	810×1015×2115 mm
<b>Packing dimensions:</b>	905×1130×2240 mm
<b>Gross weight:</b>	195 Kg
<b>Voltage:</b>	400-415 V - 50-60 Hz
<b>Total rate:</b>	610 W

### Features

<b>Functions:</b>	Blast chilling, shock freezing, continuous cycle
<b>Control:</b>	4.3" touch screen display with USB port
<b>Doors:</b>	Cushioned, with anti-odor system
<b>Door gasket:</b>	Magnetic, triple chamber and easily replaceable
<b>Core probe:</b>	Needle probe with 1 reading point, quick-release and easily replaceable
<b>Insulation:</b>	75 mm thickness - CFC/HCFC free
<b>Exterior/interior finishing:</b>	Exterior and interior AISI 304 stainless steel.
<b>Inner corners:</b>	Rounded for easy cleaning and ensuring maximum hygiene
<b>Handle:</b>	Stainless steel AISI 304, 2 mm thick
<b>Racks and slides:</b>	Stainless steel AISI 304, quick release
<b>Cosmo:</b>	Wi-Fi remote control system

## Accessories and variants

RAL customisable colouring	Alimentazione Trifase 50Hz oppure 60Hz
Sonda al cuore a 3 punti di lettura	Alimentazione frequenza 60Hz
Sonda al cuore riscaldata a 1 punto di lettura	Other special voltage
Reverse door opening from standard	Open remote condensing unit W20T
Predisposition for connection to CO2 remote control unit	Silenced faired remote condensing unit W20T
Alimentazione Monofase 50Hz oppure 60Hz	Trolley GN1/1 20 trays 598x530x1630 mm

## Remote unit technical data

<b>Voltage:</b>	400-415 V - 50-60 Hz
<b>Cooling gas:</b>	R404-R452a
<b>HP unit:</b>	3
<b>Gross weight:</b>	93 Kg
<b>Dimensions:</b>	930x680x450 mm
<b>Cooling capacity:</b>	Evap. -10°C Cond. +45°C

## COSMO - wi-fi control

Cosmo is The Nice Kitchen's exclusive wi-fi technology that allows MODI blast chillers to be connected, updated and monitored from smartphones. MODI is also a Cosmo hub and allows remote supervision of the Coldline appliances connected to it. From the CosmoApp you can check the operating conditions of each machine and receive alerts in the event of abnormal operation.

## Technical draw

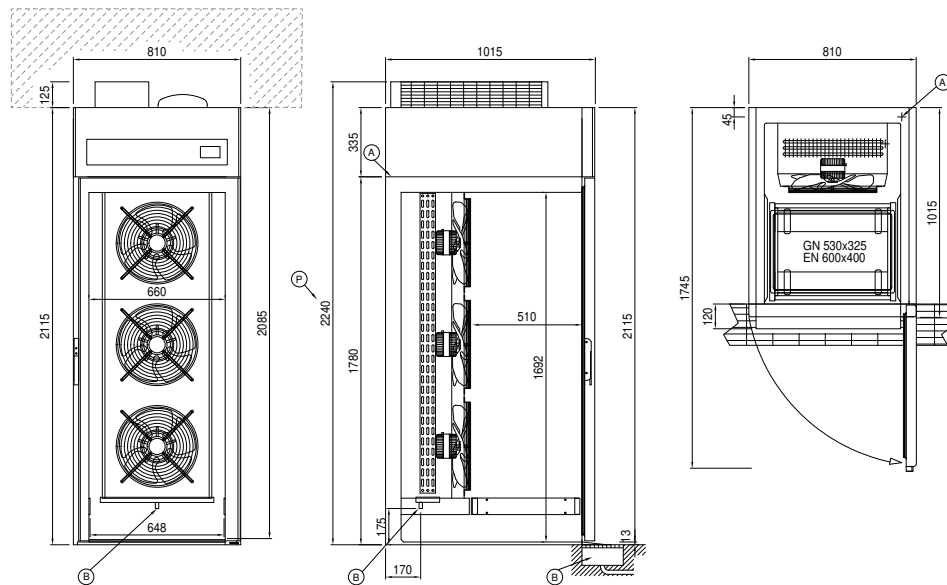

**A:** Power supply cable outlet

**B:** Condensation water drain

**Q:** Plug-In

**R:** Gas output pipes