

Client \_\_\_\_\_ Quantity \_\_\_\_\_  
 Project \_\_\_\_\_ Position \_\_\_\_\_

## Vision Industry W101K F

**Model:** W101KFR-2D

**Cod:** W81220214001



Vision Industry W101 trolley blast chiller Pass-Through F version, temperature range -40°+65°C with humidifier boiler as standard. It is equipped with the functions: blast chilling, blast freezing, manual cycle, thawing, proving, retarded proving, holding, steam sanitising. Remote cooling system with R452a refrigerant gas. Devote™ - Dynamic Evolution Temperature - the innovative system that autonomously recognises the weight, size and temperature of food and automatically shortens the blast chilling or freezing time of hot food without the use of a core probe. 7" touch screen and operating mode with customisable recipes, by time, with core probe or with Devote algorithm. Adjustable ventilation 25-100%, adjustable humidity 45-95%. Blast chilling yield +90/+3°C - 400 Kg; blast freezing yield +90/-18°C - 320 Kg. 5 heavy duty climatic class, forced air defrost. 100 mm insulation thickness - HFO with high insulation performance and low environmental impact (CFC, HCFC, HFC free). Electronic expansion valve and anti-corrosion painted evaporator. Compensation valve to reduce waiting times during frequent door openings. Easily replaceable triple chamber magnetic gasket, core probe with screw connector and led lighting. Exterior and interior AISI 304 stainless steel, interior made of "canvas" steel with special highly durable texture. fan unit and condenser cover removable without tools. Blast chiller supplied assembled. ModBus/RTU Rs485 connection as standard. Cosmo: wi-fi connection for remote monitoring via Cosmo App. When wired to Coldline counters and cabinets acts as a hub for remote monitoring of connected equipment.

### Technical data

<b>Max capacity:</b>	2 trolleys GN2/1, EN60x80
<b>Temperature range:</b>	-40°+65°C
<b>Ventilation range:</b>	25% - 100%
<b>Humidity range:</b>	45% - 95% with humidifier
<b>Humidifier:</b>	Including
<b>Refrigerant unit:</b>	remote
<b>Yield +90/+3:</b>	400 Kg
<b>Yield +90/-18:</b>	320 Kg
<b>Cooling gas:</b>	R404/R452
<b>Defrost:</b>	Forced air
<b>Valve:</b>	Electronic expansion valve
<b>Dimensions:</b>	1600×2600×2510 mm
<b>Packing dimensions:</b>	2735×1735×2550 mm
<b>Gross weight:</b>	860 Kg
<b>Voltage:</b>	400-415 V - 50-60 Hz

### Features

<b>Functions:</b>	Blast chilling, shock freezing, thawing, proving and retarder prover, holding, steam sanitizing, manualcycle
<b>Control:</b>	7" touch screen display with USB port
<b>Doors:</b>	Dictator closure to absorb sudden changes in pressure when opening and closing doors
<b>Door gasket:</b>	Magnetic, triple chamber and easily replaceable
<b>Core probe:</b>	Needle probe with 1 reading point, quick-release and easily replaceable
<b>Insulation:</b>	100 mm thickness - CFC/HCFC free
<b>Exterior/interior finishing:</b>	Internal and external in "linen canvas" steel
<b>Inner corners:</b>	Rounded base 20 mm
<b>Handle:</b>	In AISI 304 stainless steel
<b>Cosmo:</b>	Wi-Fi remote control system

## Accessories and variants

Abbattitore fornito smontato	Silenced faired remote condensing unit 4GE-23Y
Floor 20 mm high, ramp included	Faired unit with remote condenser 4GE-23Y
Reverse door opening from standard	PVC ventilation profiles W100K
Door opening turning and control panel inversion	Ramp 100 mm high. Length 913 mm W40
Door stop 100°	Ramp 140 mm high. Length 1390 mm W40
Sonda al cuore 3 punti di lettura	Trolley GN1/1 20 trays 598x530x1630 mm
Sonda al cuore riscaldata 1 punto di lettura	Trolley EN60x40 20 trays 460x620x1750 mm
Winter kit -20°C	Trolley GN2/1 20 trays 660x720x1750 mm
Winter kit -40°C	Trolley EN60x80 20 trays 660x820x1750 mm
Other special voltage	Purity C Quell ST 50 filter cartridge
Open remote condensing unit 4GE-23Y	Sanitizing detergent

## Remote unit technical data

<b>Voltage:</b>	400-415 V 3N - 50 Hz
<b>Cooling gas:</b>	R404-R452a
<b>HP unit:</b>	23
<b>Gross weight:</b>	521 Kg
<b>Dimensions:</b>	2180x1170x1208 mm
<b>Cooling capacity:</b>	Evap. -10°C Cond. +45°C

## COSMO - wi-fi control

Cosmo is The Nice Kitchen's exclusive wi-fi technology that allows VISION blast chillers to be connected, updated and monitored from smartphones. VISION is also a Cosmo hub and allows remote supervision of the Coldline appliances connected to it. From the CosmoApp you can check the operating conditions of each machine and receive alerts in the event of abnormal operation.

## Technical draw

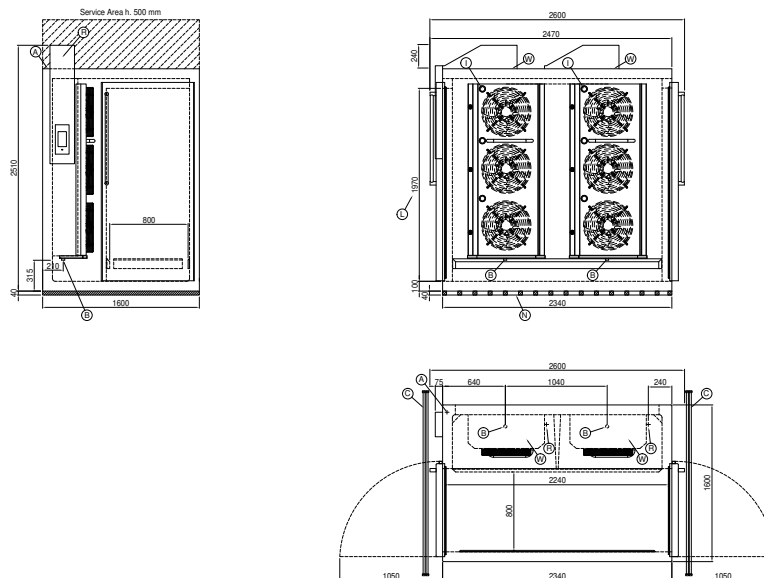

- |                                     |                                                                                       |                                                            |
|-------------------------------------|---------------------------------------------------------------------------------------|------------------------------------------------------------|
| <b>A:</b> Power supply cable outlet | <b>B:</b> Condensation water drain                                                    | <b>C:</b> Floor grid for condensate drainage (recommended) |
| <b>I:</b> Internal led lighting     | <b>L:</b> Door clear opening dimension                                                | <b>N:</b> PVC ventilation profiles                         |
| <b>R:</b> Gas output pipes          | <b>W:</b> Water mains connection for humidifier - 3/4" female. Unloading not required |                                                            |