

Client \_\_\_\_\_ Quantity \_\_\_\_\_  
 Project \_\_\_\_\_ Position \_\_\_\_\_

## Vision Industry W100K NUVO

Model: W100KHR-2D

Cod: W82220212001



Vision Industry W100 trolley blast chiller Pass-Through NUVO version, temperature range -40°+85°C with humidifier boiler as standard. It is equipped with the functions: blast chilling, blast freezing, manual cycle, thawing, proving, retarded proving, holding, steam pasteurisation, low temperature cooking with steam, steam sanitising. Remote cooling system with R452a refrigerant gas. Devote™ - Dynamic Evolution Temperature - the innovative system that autonomously recognises the weight, size and temperature of food and automatically shortens the blast chilling or freezing time of hot food without the use of a core probe. Patented NUVO™ technology for cooking food at low temperatures using steam and sequencing blast chilling or blast freezing cycles. 7" touch screen and operating mode with customisable recipes, by time, with core probe or with Devote algorithm. Adjustable ventilation 25-100%, adjustable humidity 45-95%. Blast chilling yield +90/+3°C - 320 Kg; blast freezing yield +90/-18°C - 240 Kg, 5 heavy duty climatic class, forced air defrost. 100 mm insulation thickness - HFO with high insulation performance and low environmental impact (CFC, HCFC, HFC free). Electronic expansion valve and anti-corrosion painted evaporator. Compensation valve to reduce waiting times during frequent door openings. Easily replaceable triple chamber magnetic gasket, core probe with screw connector and led lighting. Exterior and interior AISI 304 stainless steel, interior made of "canvas" steel with special highly durable texture. fan unit and condenser cover removable without tools. Blast chiller supplied assembled. ModBus/RTU Rs485 connection as standard. Cosmo: wi-fi connection for remote monitoring via Cosmo App. When wired to Coldline counters and cabinets acts as a hub for remote monitoring of connected equipment.

### Technical data

Max capacity:	2 trolleys
Temperature range:	-40°+85°C
Ventilation range:	25% - 100%
Humidity range:	45% - 95% with humidifier
Humidifier:	Including
Refrigerant unit:	remote
Yield +90/+3:	320 Kg
Yield +90/-18:	240 Kg
Cooling gas:	R404/R452
Defrost:	Forced air
Valve:	Electronic expansion valve
Dimensions:	1600×2600×2510 mm
Packing dimensions:	2735×1735×2550 mm
Net / gross weight:	770 Kg / 850 Kg
Net / gross volume:	/
Voltage:	400-415 V - 50-60 Hz
Total rate:	7540 W - 27,96 A
Cooling capacity:	29880 W*
*:	Evap. -10°C Cond. +45°C

### Features

Functions:	Blast chilling, shock freezing, thawing, proving and retarder prover, holding, steam pasteurisation, low temperature steam cooking, steam sanitizing, manual steam cycle
Control:	7" touch screen display with USB port
Doors:	Dictator closure to absorb sudden changes in pressure when opening and closing doors
Door gasket:	Magnetic, triple chamber and easily replaceable
Core probe:	Needle probe with 1 reading point, quick-release and easily replaceable
Insulation:	100 mm thickness - CFC/HCFC free
Exterior/interior finishing:	Internal and external in "linen canvas" steel
Inner corners:	Rounded base 20 mm
Handle:	In AISI 304 stainless steel
Cosmo:	Wi-Fi remote control system

In order to constantly offer the best possible products we reserve the right to make changes on technical specifications without incurring any obligation for equipment previously or subsequently sold.

## Accessories and variants

Abbattitore fornito smontato	Silenced faired remote condensing unit 4HE-18Y
Floor 20 mm high, ramp included	Faired unit with remote condenser 4HE-18Y
Reverse door opening from standard	PVC ventilation profiles W100K
Door opening turning and control panel inversion	Ramp 100 mm high. Length 913 mm W40
Door stop 100°	Ramp 140 mm high. Length 1390 mm W40
Sonda al cuore 3 punti di lettura	Trolley GN1/1 20 trays 598x530x1630 mm
Sonda al cuore riscaldata 1 punto di lettura	Trolley EN60x40 20 trays 460x620x1750 mm
Winter kit -20°C	Trolley GN2/1 20 trays 660x720x1750 mm
Winter kit -40°C	Trolley EN60x80 20 trays 660x820x1750 mm
Other special voltage	Purity C Quell ST 50 filter cartridge
Open remote condensing unit 4HE-18Y	Sanitizing detergent

## Remote unit technical data

<b>Voltage:</b>	400-415 V 3N - 50 Hz
<b>Assorbimento Unità Remota:</b>	15,4kW - 26,8A
<b>Cooling gas:</b>	R404-R452a
<b>HP unit:</b>	18
<b>Gross weight:</b>	478 Kg
<b>Dimensions:</b>	1650x1050x876 mm
<b>Pipe delivery:</b>	12 mm
<b>Pipe suction:</b>	35 mm
<b>Cooling capacity:</b>	Evap. -10°C Cond. +45°C

## COSMO - wi-fi control

Cosmo is The Nice Kitchen's exclusive wi-fi technology that allows VISION blast chillers to be connected, updated and monitored from smartphones. VISION is also a Cosmo hub and allows remote supervision of the Coldline appliances connected to it. From the CosmoApp you can check the operating conditions of each machine and receive alerts in the event of abnormal operation.

## Technical draw

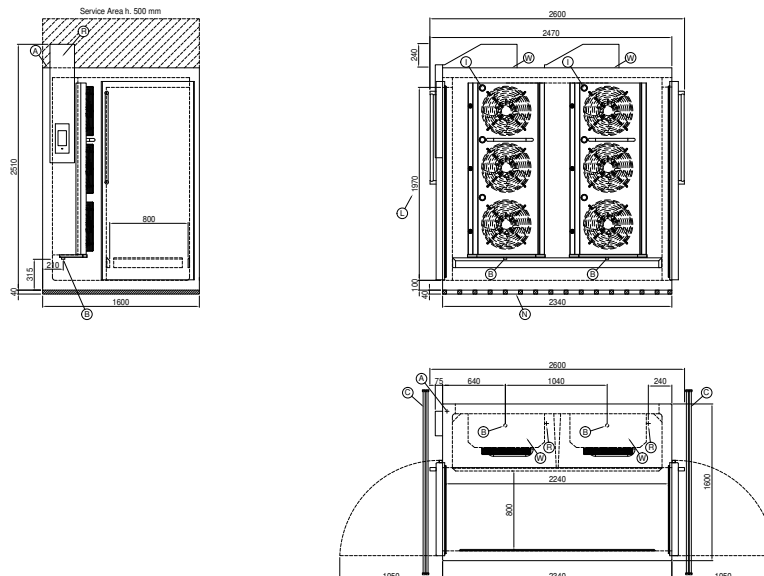

<b>A:</b>	Power supply cable outlet	<b>B:</b>	Condensation water drain	<b>C:</b>	Floor grid for condensate drainage (recommended)
<b>I:</b>	Internal led lighting	<b>L:</b>	Door clear opening dimension	<b>N:</b>	PVC ventilation profiles
<b>R:</b>	Gas output pipes	<b>W:</b>	Water mains connection for humidifier - 3/4" female. Unloading not required		

In order to constantly offer the best possible products we reserve the right to make changes on technical specifications without incurring any obligation for equipment previously or subsequently sold.