

Client _____ Quantity _____
 Project _____ Position _____

Roll-in Vision JF80

Model: JF80/1KT

Cod: J61802900101



Vision JF80 retarder prover cabinet, 1 door, temperature range -30°+40°C. It is equipped with the functions: retarded proving, manual proving, continuous cycle, storage, thawing, chocolate, ice cream. Plug-in refrigeration unit, 5 heavy duty climatic class and R290 ecological refrigerant gas. Hot gas defrost, adjustable ventilation 25-100% and adjustable humidity 45-95%. Water purification filter. 7" touch screen and operating mode with customisable recipes. For trolley EN60x80, access ramp included. led strip lighting, water drain, Electronic expansion valve and anti-corrosion painted evaporator. 100 mm insulation thickness - HFO with high insulation performance and low environmental impact (CFC, HCFC, HFC free); easily replaceable triple chamber magnetic gasket. AISI 304 stainless steel handle and magnetic triple chamber door gasket, easily replaceable. Interior/exterior AISI 304 stainless steel; external back in galvanised steel. 2 compressors and 2 independent refrigeration circuits. Cosmo: wi-fi connection for remote monitoring via Cosmo App. When wired to Coldline counters and cabinets acts as a hub for remote monitoring of connected equipment.

Technical data

| | |
|----------------------------|---------------------------------|
| Max capacity: | 2 trolleys EN60x40 |
| Gross capacity: | 1558 lt |
| Temperature range: | -30°+40°C |
| Humidity range: | 45% - 95% with humidifier |
| Humidifier: | Including |
| Refrigerant unit: | Plug-in |
| Climate class: | 5 |
| Cooling gas: | R290 |
| Defrost: | Hot gas |
| Valve: | Supplied standard with solenoid |
| Dimensions: | 960×1276×2465 mm |
| Packing dimensions: | 980×1240×2630 mm |
| Gross weight: | 317 Kg |
| Voltage: | 220-240 V - 50 Hz |
| Total rate: | 1890 W |
| Absorbed Current: | 8,6 A |
| Cooling capacity: | 1292 W* |
| *: | Evap. -30°C Cond. +55°C |

Features

| | |
|-------------------------------------|---|
| Functions: | Retarder prover, manual proving, continuous cycle, storage, chocolate, thawing, ice cream |
| Standard equipment: | LED lighting |
| Control: | 7" touch screen display with USB port |
| Doors: | 1 door, self-closing, reversible with 105° stop |
| Door gasket: | Magnetic, triple chamber and easily replaceable |
| Insulation: | 100 mm thickness - CFC/HCFC free |
| Exterior/interior finishing: | One-piece structure in AISI 304 stainless steel. Back in galvanized steel |
| Inner corners: | Rounded for easy cleaning and ensuring maximum hygiene |
| Handle: | Snap-in chrome with integrated lock |
| Cosmo: | Wi-Fi remote control system |

Accessories and variants

| | |
|------------------------------|--|
| RAL customisable colouring | Other special voltage |
| Plug-in water unit | Purity C Quell ST 50 filter cartridge |
| Alimentazione frequenza 60Hz | Trolley EN60x80 20 trays 660x820x1750 mm |

COSMO - wi-fi control

Cosmo is The Nice Kitchen's exclusive wi-fi technology that allows VISION retarder provers to be connected, updated and monitored from smartphones. VISION is also a Cosmo hub and allows remote supervision of the Coldline appliances connected to it. From the CosmoApp you can check the operating conditions of each machine and receive alerts in the event of abnormal operation.

Technical draw

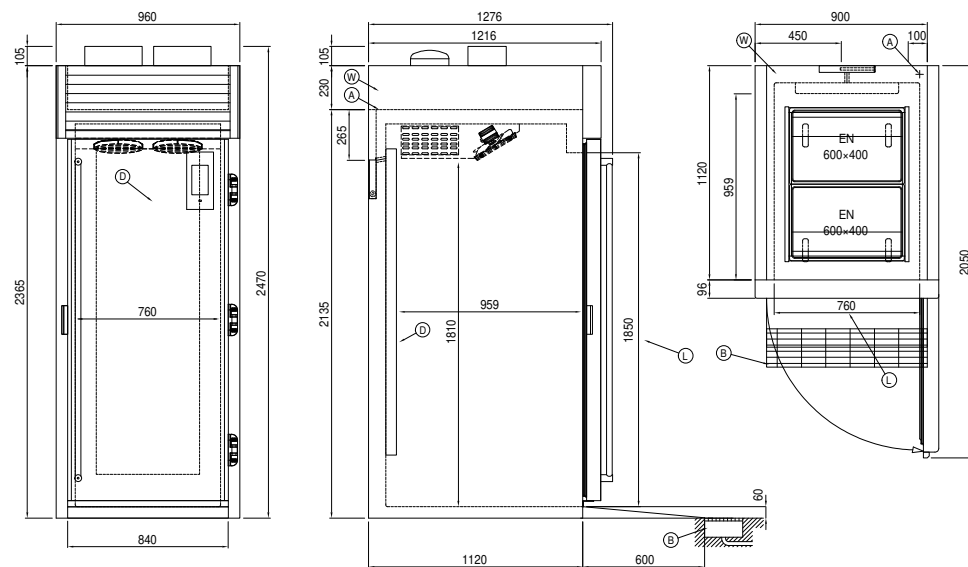

- A:** Power supply cable outlet
- B:** Condensation water drain
- D:** Airflow conveyor
- L:** Door clear opening dimension
- W:** Water mains connection for humidifier - 3/4" female. Unloading not required